

General Standards Corporation
High Performance Bus Interface Solutions

Rev: 022007

PMC-24DSI12

**24-BIT, 12-CHANNEL DELTA-SIGMA, 200 KSPS
ANALOG INPUT PCI BOARD**

REFERENCE MANUAL

Copyright (C) 2007 General Standards Corp.

Additional copies of this manual or other General Standards Co. literature may be obtained from:

General Standards Corp.
8302A Whitesburg Dr.
Huntsville, Alabama 35802
Telephone: (256) 880-8787
FAX: (256) 880-8788

The information in this document is subject to change without notice.

General Standards Corp. makes no warranty of any kind with regard to this material, including, but not limited to, the implied warranties of merchantability and fitness for a particular purpose. Although extensive editing and reviews are performed before release to ECO control, General Standards Corp. assumes no responsibility for any errors that may exist in this document. No commitment is made to update or keep current the information contained in this document.

General Standards Corp. does not assume any liability arising out of the application or use of any product or circuit described herein, nor is any license conveyed under any patent rights or any rights of others.

General Standards Corp. assumes no responsibility resulting from omissions or errors in this manual, or from the use of information contained herein.

General Standards Corp. reserves the right to make any changes, without notice, to this product to improve reliability, performance, function, or design.

All rights reserved.

No part of this document may be copied or reproduced in any form or by any means without prior written consent of General Standards Corp.

TABLE OF CONTENTS

<u>SECTION</u>	<u>TITLE</u>	<u>PAGE</u>
1.0	INTRODUCTION	1-1
1.1	General Description	1-1
1.2	Functional Overview	1-2
2.0	INSTALLATION AND MAINTENANCE	2-1
2.1	Board Configuration	2-1
2.2	Installation	2-1
2.2.1	Physical Installation	2-1
2.2.2	Input/Output Cable Connections	2-1
2.3	Analog Input Configuration	2-2
2.3.1	Differential Inputs	2-3
2.3.2	Single-ended Input Sources	2-4
2.4	Multiboard Clocking and Synchronization	2-4
2.4.1	Interboard Connections	2-4
2.4.2	Multiboard Synchronization	2-5
2.5	Maintenance	2-5
2.6	Reference Verification and Adjustment	2-5
2.6.1	Equipment Required	2-6
2.6.2	Adjustment Procedure	2-6
3.0	CONTROL SOFTWARE	3-1
3.1	Introduction	3-1
3.2	Board Control Register	3-1
3.3	Configuration and Initialization	3-3
3.3.1	Configuration	3-3
3.3.2	Initialization	3-3
3.4	Analog Input Configuration	3-4
3.4.1	Selftest Modes	3-4
3.4.2	Input Range Selection	3-4
3.4.3	Settling Delays and the Channels Ready Flag	3-5
3.5	Input Data Buffer	3-5
3.5.1	General Characteristics	3-5
3.5.2	Data Organization	3-5
3.5.2.1	Channel Tags	3-5
3.5.2.2	Input Data Format	3-6

TABLE OF CONTENTS (Continued)

<u>SECTION</u>	<u>TITLE</u>	<u>PAGE</u>
3.5	Input Data Buffer (cont)	---
3.5.3	Buffer Control Register	3-6
3.5.3.1	Status Flag and Threshold	3-7
3.5.3.2	Buffer Clearing and Disabling	3-7
3.5.4	Buffer Size Register	3-7
3.5.5	Buffer Underflow and Overflow Flags	3-7
3.6	Input Sampling Control	3-8
3.6.1	Sample Rate Control	3-8
3.6.1.1	Rate Clock Organization	3-8
3.6.1.2	Rate Generator Assignment	3-8
3.6.1.3	Sample Clock Generation	3-10
3.6.1.4	Rate Generator Control	3-11
3.6.1.4.1	PLL Rate Generators	3-11
3.6.1.4.2	Legacy Rate Generators	3-13
3.6.1.5	Direct External Clocking	3-14
3.6.1.6	Harmonically Locked Channels	3-14
3.6.2	Channel Synchronization	3-14
3.6.3	Multiboard Operation	3-15
3.6.3.1	External Sample Clock	3-15
3.6.3.2	External Sync	3-15
3.7	Autocalibration	3-16
3.8	Interrupt Control	3-17
3.8.1	Local Interrupt Request	3-17
3.8.2	Enabling the PCI Interrupt	3-17
3.9	DMA Operation	3-18
3.10	Scan Synchronization	3-19
3.11	Board Configuration Register	3-21
4.0	PRINCIPLES OF OPERATION	4-1
4.1	General Description	4-1
4.2	Analog Inputs	4-2
4.3	Autocalibration	4-2
4.4	Sampling Clocks	4-3
4.5	Power Control	4-3
Appendix A	Local Register Quick Reference	A-1
Appendix B	Similarities to PCI-24DSI32	B-1

LIST OF ILLUSTRATIONS

FIGURE	TITLE	PAGE
1.1	Physical Configuration	1-1
1.2	Functional Organization	1-2
2.2.2	System I/O Connections	2-2
2.3.1	Input Configurations	2-3
2.4.1	Multiboard Clock/Sync Connections	2-4
2.6.2	Reference Adjustment Access	2-6
3.6.1.1	ADC Clock and Sync Organization, 12 Channels	3-9
4.1	Functional Block Diagram	4-1

LIST OF TABLES

TABLE	TITLE	PAGE
2.2.2	System Connector Pin Assignments	2-2
2.6.1	Reference Adjustment Equipment	2-6
3.1	Control and Data Registers	3-1
3.2	Board Control Register	3-2
3.3.1	Configuration Operations	3-3
3.4	Analog Input Function Selection	3-4
3.4.2	Analog Input Range Selection	3-4
3.5.2	Input Data Buffer Organization	3-5
3.5.2.2	Analog Input Data Coding; 16-Bit Data Field	3-6
3.5.3	Buffer Control Register	3-6
3.6.1.1	Channel Groups	3-9
3.6.1.2-1	Rate Assignments Register	3-10
3.6.1.2-2	Rate Generator Assignment Codes	3-10
3.6.1.3	Rate Divisor Register	3-10
3.6.1.4-1	PLL Rate Control Registers	3-12
3.6.1.4-2	Summary of PLL Sample Rate Control Parameters	3-12
3.6.1.4-3	Legacy Rate Control Registers	3-13
3.6.1.5	Direct External Clocking	3-14
3.8.1	Interrupt Event Selection	3-17
3.9.1	Typical DMA Register Configuration	3-18
3.10.1	Channel Order	3-19
3.11.1	Board Configuration Register	3-21

SECTION 1.0 INTRODUCTION

1.1 General Description

The PMC-24DSI12 board provides 24-bit analog input capability for the PCI bus at sample rates up to 200 KSPS per channel. In addition to providing 12 analog input channels, this product supports multiboard clocking and synchronization. The board is functionally and mechanically compatible with the IEEE PCI local bus specification Revision 2.3, and supports the "plug-n-play" initialization concept. Power requirements consist of +5 VDC in accordance with the PCI specification, and operation over the specified temperature range is achieved with minimal air cooling. Specific details pertaining to physical characteristics and performance are contained in the PMC-24DSI12 product specification.

The board is designed for minimum off-line maintenance, and includes internal monitoring features that eliminate the need for disconnecting or removing the module from the system for calibration. All system input and output connections are made at the front panel through a 68-Pin dual-ribbon cable connector. Figure 1.1 represents the physical configuration of the board.

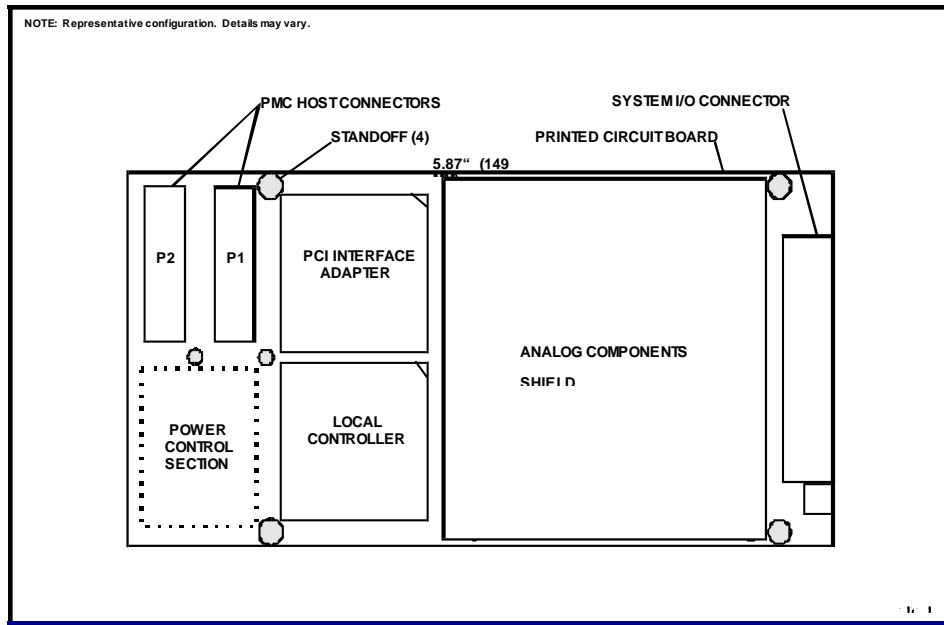

Figure 1.1. Physical Configuration

1.2 Functional Overview

A PCI interface adapter provides the interface between the controlling PCI bus and the internal local controller through a 32-bit local bus (Figure 1.2). Inputs are organized into two channel groups, either of which can be designated as either active or inactive independently of the group. Each input channel provides configuration switches for selftest and autocalibration operations, as well as range-scaling and analog image filter networks. Each even-odd channel pair also contains a dual delta-sigma A/D converter (ADC) that provides two separate but synchronized conversion channels. An internal voltage reference can be applied to all channels to support selftest operations and autocalibration. Gain and offset trimming of the input channels is performed by applying correction values obtained during autocalibration.

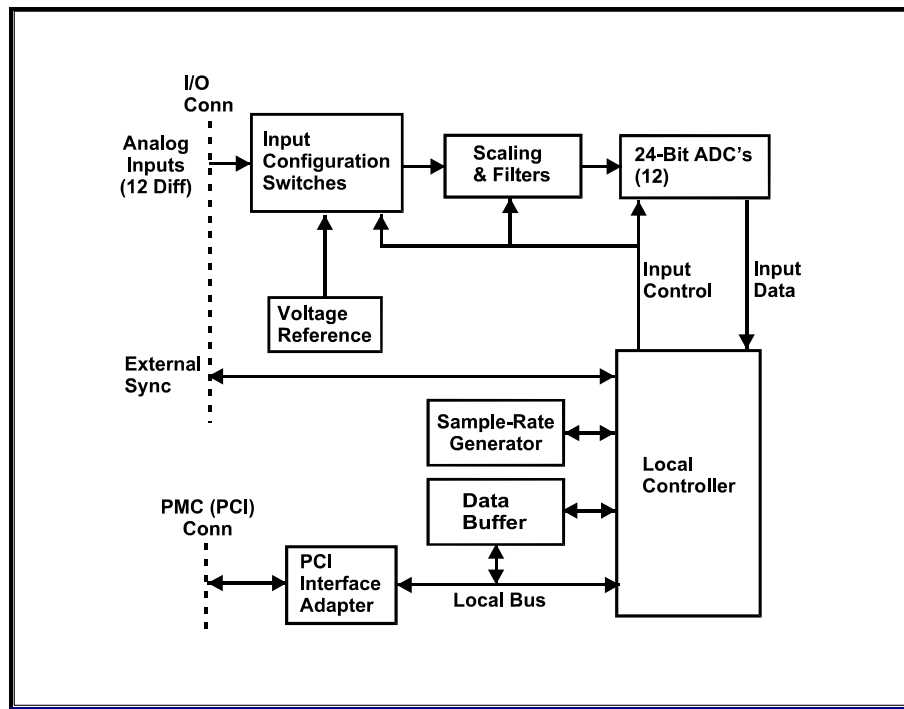

Figure 1.2. Functional Organization

An internal sample-rate clock generator is adjustable from 25.6 MHz to 51.2 MHz, and is divided down within the local controller to provide sample rates from 2.0 KSPS to 200 KSPS. Input bandwidth extends down to DC. Conversion data from all active channels is transferred to the PCI bus through a 256K-sample FIFO data buffer.

Multiple channels can be synchronized to perform sampling in "lockstep", either by a software command, or by external hardware sync and clock input signals. Hardware sync and clock input/output signals permit multiple boards to be connected together for phase-locked operation from a common clock.

SECTION 2.0

INSTALLATION AND MAINTENANCE

2.1 Board Configuration

This product has no field-alterable configuration features, and is completely configured at the factory for field use.

2.2 Installation

2.2.1 Physical Installation

To minimize the opportunity for accidental damage before installation, the board should be stored in the original protective shipping envelope. System power must be turned OFF before proceeding with the installation.

CAUTION: This product is susceptible to damage from electrostatic discharge (ESD). Before removing the board from the conductive shipping envelope, ensure that the work surface, the installer and the host system are adequately discharged to ground.

After removing the board from the shipping envelope, position the board with the shield and standoffs facing the host (carrier) board, and with the I/O connector oriented toward the front panel. Align the two PCI connectors located at the end of the board opposite the I/O connector, with the corresponding mating connectors on the host board. Then carefully press the board into position on the host. Verify that the PCI connectors have mated completely and that the standoffs are seated against the host board.

Attach the board to the host with four 2.5 x 6.5mm panhead screws. Pass the screws through the back of the host into the four mounting holes on the board. Tighten the screws carefully to complete the installation. Do not overtighten.

2.2.2 Input/Output Cable Connections

System cable signal pin assignments are listed in Table 2.2.2. Unused input pins may be left disconnected in most applications. However, if very long cables are used or if excessive cable noise is anticipated, the unused analog inputs should be grounded to the input return to minimize the injection of noise into the board.

The system I/O connector is designed to mate with a 68-pin dual-ribbon connector, equivalent to AMP #749621-7. This insulation displacement (IDC) cable connector accepts two 34-wire 0.050-inch ribbon cables, with the pin numbering convention shown in Table 2.2.2 and in Figure 2.2.2.

Table 2.2.2. System Connector Pin Assignments

ROW-A		ROW-B	
PIN	FUNCTION	PIN	FUNCTION
1	INPUT RETURN	1	INPUT RETURN
2	INPUT RETURN	2	INPUT RETURN
3	INP CHAN 00 LO	3	INP CHAN 06 LO
4	INP CHAN 00 HI	4	INP CHAN 06 HI
5	INPUT RETURN	5	INPUT RETURN
6	INPUT RETURN	6	INPUT RETURN
7	INP CHAN 01 LO	7	INP CHAN 07 LO
8	INP CHAN 01 HI	8	INP CHAN 07 HI
9	INPUT RETURN	9	INPUT RETURN
10	INPUT RETURN	10	INPUT RETURN
11	INP CHAN 02 LO	11	INP CHAN 08 LO
12	INP CHAN 02 HI	12	INP CHAN 08 HI
13	INPUT RETURN	13	INPUT RETURN
14	INPUT RETURN	14	INPUT RETURN
15	INP CHAN 03 LO	15	INP CHAN 09 LO
16	INP CHAN 03 HI	16	INP CHAN 09 HI
17	INPUT RETURN	17	INPUT RETURN
18	INPUT RETURN	18	INPUT RETURN
19	INP CHAN 04 LO	19	INP CHAN 10 LO
20	INP CHAN 04 HI	20	INP CHAN 10 HI
21	INPUT RETURN	21	INPUT RETURN
22	INPUT RETURN	22	INPUT RETURN
23	INP CHAN 05 LO	23	INP CHAN 11 LO
24	INP CHAN 05 HI	24	INP CHAN 11 HI
25	VTEST RETURN	25	INPUT RETURN
26	VTEST	26	INPUT RETURN
27	DIGITAL RETURN	27	DIGITAL RETURN
28	DIGITAL RETURN	28	DIGITAL RETURN
29	EXT CLK INP LO	29	EXT CLK OUT LO
30	EXT CLK INP HI	30	EXT CLK OUT HI
31	DIGITAL RETURN	31	DIGITAL RETURN
32	DIGITAL RETURN	32	DIGITAL RETURN
33	EXT SYNC INP LO	33	EXT SYNC OUT LO
34	EXT SYNC INP HI	34	EXT SYNC OUT HI

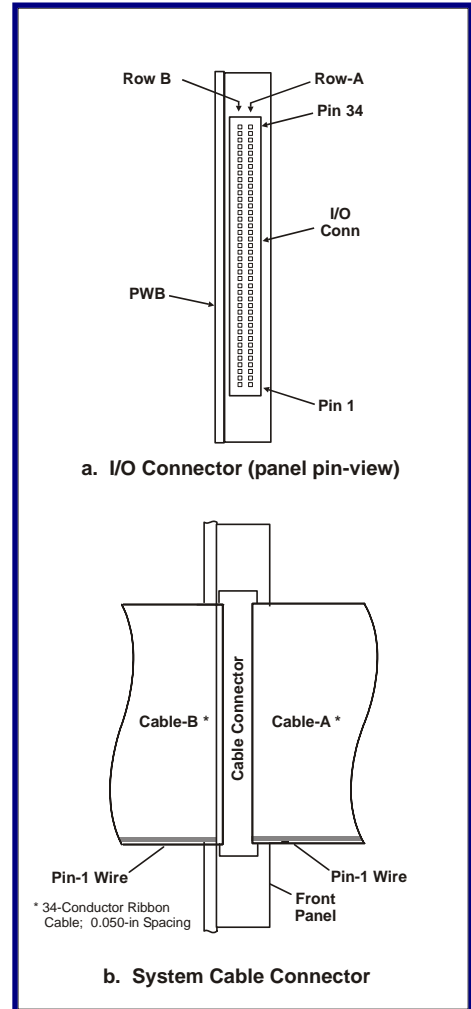

Figure 2.2.2: System I/O Connections

2.3 Analog Input Configuration

The analog inputs are configured as 12 differential input pairs. Differential operation provides the highest noise immunity, and is recommended for the majority of applications. Pull-down resistors are provided on all analog inputs. Although the input configuration is differential, single-ended signal sources can be accommodated as described in Paragraph 2.3.2.

2.3.1 Differential Inputs

Differential operation is essential when the input source returns are at different potentials. This operating mode also offers the highest rejection of the common mode noise that is characteristic of long unshielded cables. When operating in the differential mode, shown in Figure 2.3.1a, the wire pair from each signal source is connected between the HI(+) and LO(-) inputs of a single input channel. The input return should be connected to system ground (remote common) as closely as possible to the input sources. The average HI/LO signal level relative to the input return is the common mode voltage **V_{cm}** which, for optimum performance, must not exceed the maximum value indicated in the product specification.

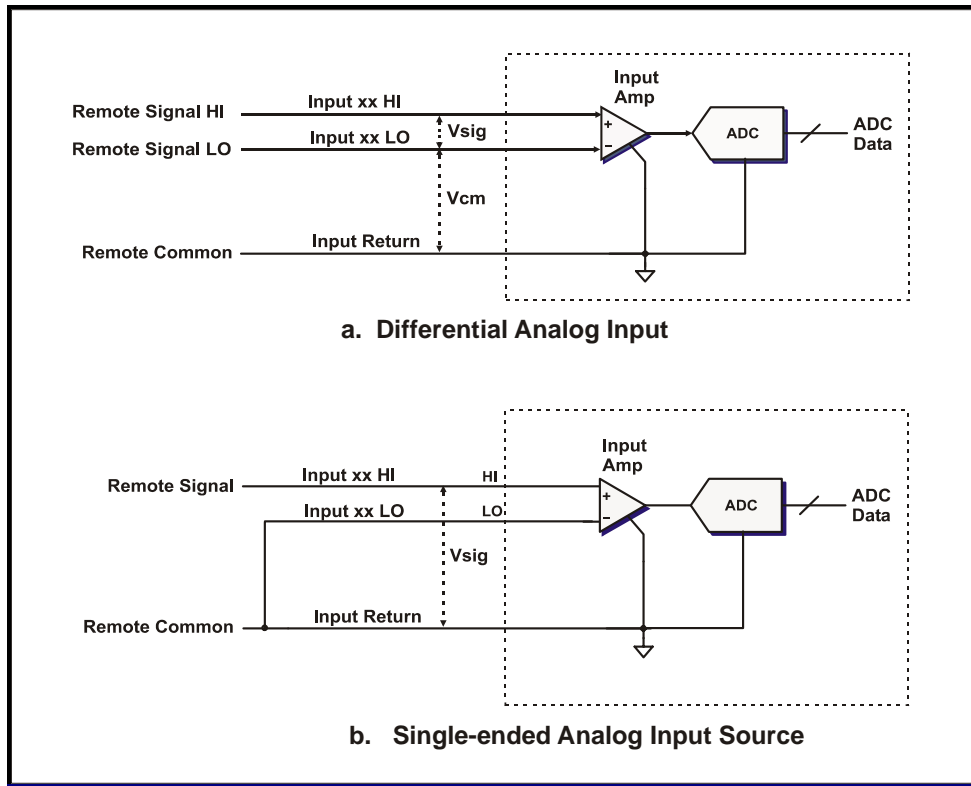

Figure 2.3.1. Input Configurations

2.3.2 Single-Ended Input Sources

Single-ended signal sources can be accommodated as shown in Figure 2.3.1b, with the signal line connected to INP CHAN XX HI, and the associated INP CHAN XX LO input connected to INPUT RETURN at the source. The single-ended operating connection provides suitable performance only when the input signal sources either are isolated from each other, or are common only to a single isolated signal return.

CAUTION: If a significant potential difference exists between the remote signal return and INPUT RETURN, a low impedance between the two returns can cause excessive current to flow, which in turn can cause erroneous measurements or possible damage to the board. Return-current should be controlled to less than a few milliamps for best performance, and to less than 100 milliamps to avoid damage.

2.4 Multiboard Clocking and Synchronization

Analog input converters on multiple boards can be:

- a. Clocked from a single clock source (Multiboard clocking), and/or:
- b. Synchronized to a common time reference (Multiboard synchronization).

Clocking multiple converters from a single source prevents the *sampling drift* that occurs when converters are clocked from different sources. *Synchronizing* the converters on multiple boards causes the converters to initiate conversions simultaneously, and can be used to eliminate *sampling skew* between channels.

2.4.1 Interboard Connections

Figure 2.4.1 illustrates how multiple PMC-24DSI12 boards can be daisy-chained together in an initiator-target sequence to provide common clocking between boards. The CLOCK OUTPUT HI/LO lines from an initiator are connected to the CLOCK INPUT HI/LO lines on a target board, and the SYNC output and input pairs are connected similarly. Each target board can serve as an initiator for another target board, and multiple boards can be daisy-chained together for synchronous operation.

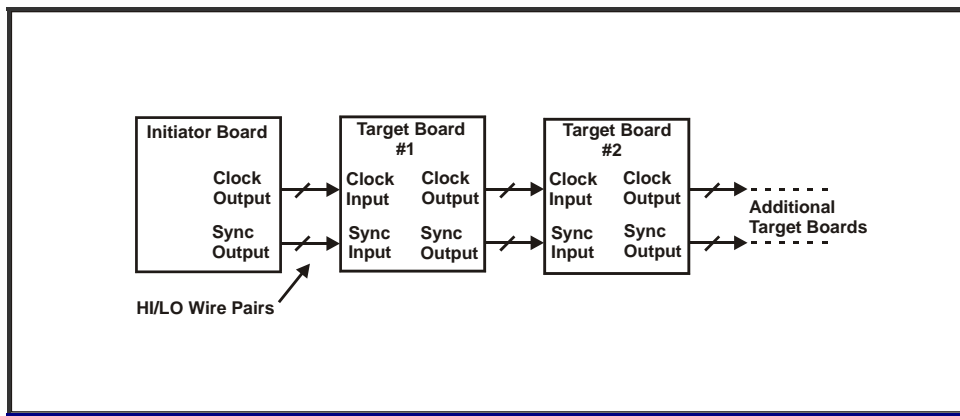

Figure 2.4.1. Multiboard Clock/Sync Connections

By using an external clock and sync distribution module, multiple boards can be interconnected in a 'star' configuration to eliminate the clock and sync propagation delay introduced by each board in a daisy chain configuration.

The clock output signal is generated internally on an initiator board, or is a duplicate of the clock input signal on a target board. Similarly, the sync output is the software-generated sync signal on an initiator board, or a duplicate of the sync input signal on a target board.

Note: External clock and sync inputs can be provided from external sources other than an initiator board, and can software-configured for either single-ended TTL or differential LVDS logic levels. As a general rule, LVDS levels should be used in applications requiring I/O cable lengths that exceed 20-30 centimeters (10 inches).

In the TTL configuration, clock and sync inputs and outputs are connected through the "HI" I/O pins. LO inputs must be left open or disconnected, and the LO outputs are inactive. TTL signals are referenced to DIGITAL RETURN.

Because each board provides active clock and sync outputs for the next board in the chain, the number of boards in the chain is limited only if the propagation delay of approximately 10 nanoseconds introduced by each board becomes significant through multiple boards. For LVDS clock and sync I/O configurations, cable-length between boards should not exceed one meter for general-purpose ribbon cable, while high-quality 100-Ohm cable can extend the length to 10 meters or more.

Application software controls the designation of each board as an initiator or a target, and also selects the channels on each board that will respond to the external clock. Although only software-designated channels respond to the external clock, all channels on all target boards respond to the external sync input.

2.4.2 Multiboard Synchronization

Boards that are interconnected for multiboard synchronization initiate internal *synchronization sequences* each time a sync pulse is generated by the initiator board. The sync I/O can also be used to reset (clear) the data buffers on target boards.

2.5 Maintenance

This product requires no scheduled hardware maintenance other than periodic reference verification. The optimum adjustment interval will vary, depending upon the specific application, but in most instances an interval of one year is recommended. In the event of a suspected malfunction, all associated system parameters, such as I/O cabling, power voltages, and control bus integrity should be evaluated before a board is returned to the factory for problem analysis and repair.

2.6 Reference Verification and Adjustment

All input and output channels are software-calibrated to an internal voltage reference by an embedded autocalibration software utility. This procedure describes the adjustment of the internal reference. For applications in which the system must not be powered down, the adjustment can be performed while the board is installed in an operating system.

2.6.1 Equipment Required

Table 2.6.1 lists the equipment requirements for calibrating the PMC-24DSI12 board. Alternative equivalent equipment may be used.

Table 2.6.1. Reference Adjustment Equipment

EQUIPMENT DESCRIPTION	MANUFACTURER	MODEL
Digital Multimeter, 5-1/2 digit, 0.005% accuracy for DC voltage measurements at +10 Volts.	Hewlett Packard	34401A
Host system with PCI expansion slot	---	---
Cable connector, with test leads. (Not required if calibration test points are made permanently available at a system connection point)	AMP	749621-9

2.6.2 Adjustment Procedure

The following procedure describes the single adjustment that is necessary to ensure conformance to the product specification. Adjustment of the internal reference (V_{test}) is performed with an internal trimmer that is accessible at the top of the board, as shown in Figure 2.6.2.

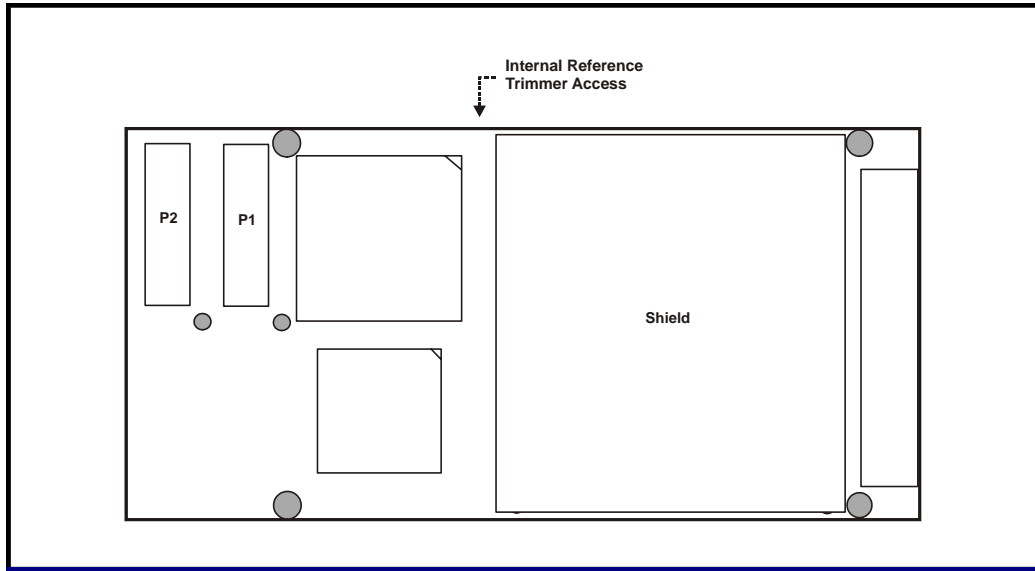

Figure 2.6.2. Reference Adjustment Access

This procedure assumes that the board is installed in an operating system, and that the $\pm 10\text{V}$ input range is selected.

1. Connect the digital multimeter between the VTEST OUTPUT (+) and VTEST RETURN (-) pins in the system I/O connector. Refer to Table 2.2.2 for pin assignments.
2. If power has been removed from the board, apply power now and wait at least 15 minutes before proceeding.
3. Select the $\pm 10\text{V}$ input range.
4. Verify that the digital multimeter indication is $+9.9000\text{ VDC} \pm 0.0009\text{ VDC}$. If the indication is not within this range, adjust the REFERENCE ADJUSTMENT trimmer until the digital multimeter indication is within the specified range.

SECTION 3.0

CONTROL SOFTWARE

3.1 Introduction

The PMC-24DSI12 board is compatible with the PCI Local Bus specification and supports "plug-n-play" autoconfiguration at the time of power-up. That is, the host can obtain the amount of I/O space required by the board, and return the configuration base address into the PCI Configuration Register on this board. The PCI interface is controlled by a PLX™ PCI-9080 PCI adapter. Configuration-space registers are initialized internally to support the location of the board on any 32-longword boundary in memory space.

After initialization, communication between the PCI bus and the board takes place through the control and data registers shown in Table 3.1. All data transfers are long-word D32. Reserved bits in each register are ignored during write operations, and are forced LOW during read operations. To ensure compatibility of applications with subsequent product upgrades, reserved bits should be written as LOW.

Table 3.1. Control and Data Registers

LOCAL ADDR	ACCESS MODE *	REGISTER	DEFAULT	DESCRIPTION
00	R/W	Board Control (BCR)	0000 383Ch *	Board Control Register (BCR)
04	R/W	Rate Control A	0040 0032h	Rate Generator-A control
08	R/W	Rate Control B	0040 0032h	Rate Generator-B control.
0C	R/W	Rate Assignments	0000 0000h	Channel-group rate generator assignment
10	R/W	Rate Divisors	0000 0505h	Channel-group sample rate divisors.
14	RO	(Reserved)	0000 0000h	---
18	RO	PLL Reference Freq	XXXX XXXXh	PLL reference frequency indicator.
1C	RO	(Reserved)	0000 0000h	---
20	R/W	Buffer Control	0003 FFEh **	Input buffer control and status
24	RO	Board Configuration	00XX XXXXh	Installed firmware and hardware options
28	RO	Buffer Size	0XXX XXXXh	Number of ADC values in the input buffer.
2C	RO	Autocal Values ***	---	---
30	RO (DMA)	Input Data Buffer	XXXX XXXXh	Input Data Buffer; Data and channel tag
34-7C	--	(Reserved)	---	---

* Changes to 0000 783Ch when the input buffer fills.

** Changes to 0103 FFEh when the buffer fills.

R/W = Read/Write; RO = Read-Only.

*** Maintenance register; Shown for reference only.

3.2 Board Control Register

The Board Control Register (BCR) controls primary board functions, including analog input mode and analog input range, and consists of 32 control bits and status flags. Table 3.2 provides a brief description of each bit field in the BCR, as well as indicating an associated section in the text.

Table 3.2. Board Control Register

Offset: 0000h

Default: 0000 383Ch **

DATA BIT	MODE	DESIGNATION	DESCRIPTION	SECTION
D00	R/W	AIM0	Analog input mode. Selects system inputs or selftest mode. Defaults to system inputs.	3.4
D01	R/W	AIM1		
D02	R/W	RANGE0	Analog input range selection. Defaults to $\pm 10V$ range.	3.4.2
D03	R/W	RANGE1		
D04	R/W	OFFSET BINARY	Selects offset binary or two's complement input data format. Defaults HIGH to offset binary.	3.5.2.2
D05	R/W	INITIATOR	Selects INITIATOR or TARGET mode for external clock and sync signals. Defaults to Initiator mode.	3.6.3
D06	R/W	*SOFTWARE SYNC	Initiates a local ADC sync operation when asserted. Also generates an external sync output if INITIATOR mode is selected. Clears automatically.	3.6.3.2
D07	R/W	*AUTOCAL	Initiates an autocalibration operation when asserted. Clears automatically upon completion.	3.7
D08	R/W	INTERRUPT A0	Interrupt event selection. Default is zero. Set HIGH when the board requests an interrupt. Clears the request when cleared LOW by the bus.	3.8.1
D09	R/W	INTERRUPT A1		
D10	R/W	INTERRUPT A2		
D11	R/W	INTERRUPT REQUEST FLAG		
D12	RO	AUTOCAL PASS	Set HIGH at reset or autocal initialization. Cleared LOW if autocalibration terminates unsuccessfully.	3.7
D13	RO	CHANNELS READY	LOW during any change in channel parameters. Asserted HIGH when ADC clocks are stabilized.	3.4.3
D14	RO	BUFFER THRESHOLD FLAG	Asserted HIGH when buffer contents exceed the assigned threshold.	3.5.3.1
D15	R/W	*INITIALIZE	Initializes the board when asserted HIGH.	3.3.2
D16	R/W	ASYNCHRONOUS SCAN	Disables synchronous sampling mode when HIGH .	3.10
D17	R/W	CLEAR BUFFER ON SYNC	Changes the context of the SOFTWARE SYNC control bit changes to CLEAR BUFFER.	3.5.3.2
D18	R/W	RATE-A EXT CLOCK OUT (Initiator Mode only)	When HIGH: Selects the Rate-A generator as the external clock output source. When LOW: Selects the Group-00 sample clock as the output. (If Group-00 external clocking is selected, the output is driven by the Rate-A generator and the Group-00 divisor).	3.6.3.1
D19	R/W	LOW FREQ FILTER	Selects the low-frequency image filter when HIGH, or the high-frequency filter when LOW.	3.4
D20	R/W	TTL EXTERNAL SYNC I/O	Selects TTL external sync I/O configuration.	3.6.3
D21-31	RO	(Reserved)	---	---

* Cleared automatically.

R/W = Read/Write; RO = Read-Only.

** Changes to 0000 783Ch when the input buffer fills.

3.3 Configuration and Initialization

3.3.1 Configuration

Configuration is initiated by a PCI bus RESET, and should be required only once after the initial application of power. During board configuration, initial values for both the PCI configuration registers and the internal control logic are extracted from internal nonvolatile read-only memory. While the PCI configuration registers are being loaded, the response to PCI target accesses is RETRY's. Configuration operations are executed in the sequence shown in Table 3.3.1.

Table 3.3.1. Configuration Operations

Operation	Maximum Duration
PCI configuration registers are loaded from internal EEPROM	3 ms
Internal control logic is configured from internal ROM	300 ms
Internal control logic is initialized	3 ms
A/D converters and clocks are initialized	5 seconds

Board configuration terminates with the PCI interrupts disabled. Attempts to access the local bus during configuration should be avoided until the PCI interrupts are enabled and the initialization-complete interrupt request is asserted.

3.3.2 Initialization

Internal control logic can be initialized without invoking configuration by setting the INITIALIZE control bit in the BCR. This action causes the internal logic to be initialized, but does not affect the PCI configuration registers and does not reconfigure the internal control logic. Initialization has a maximum duration of 5 seconds, and produces the following conditions:

- The Initiator mode is selected, External clock output is Channel-00 sample clock,
- Synchronous Scanning is selected,
- The width of the buffer data field is adjusted to 16 bits,
- Rate generator(s) are adjusted to 25.6 MHz,
- Rate divisor(s) are preset to 5,
- Sample rates are 10 KSPS; i.e.: 25.6MHz / (512 *5).
- Both channel groups are controlled by rate generator A.
- The analog input buffer is reset to empty; buffer threshold equals 0003 FFFEh
- Analog inputs are configured for ±10 Volt operation
- All control registers are initialized; all defaults are invoked
- The local interrupt request is asserted as an initialization-completed event.

Upon completion of initialization, the INITIALIZE control bit is cleared automatically.

3.4.3 Settling Delays and the Channels Ready Flag

When a critical parameter such as input mode or sample rate is changed, a settling transition occurs during which input measurements are unpredictable. A settling delay is inserted automatically when any or all of these parameters are changed, and the CHANNELS READY status flag in the BCR goes LOW during the delay. A LOW-to-HIGH transition of this flag is selectable as an interrupt request "channels ready" event (Section 3.8.1). The CHANNELS READY flag goes low during the following operations for the approximate intervals indicated:

- 5 Seconds: Board initialization (3.3),
- 1 us: Buffer reset, if not in synchronous-scanning mode (3.5.3.2),
- 10 us-5 ms: Buffer reset, if in synchronous-scanning mode (3.5.3.2),
- 500 ms: Sample rate change ; i.e.: Nrate, Ndiv, Rate assignments (3.6).
- 1-500 ms: ADC synchronization (3.6.2 and 3.10),
- 1-500 ms: Synchronous-scan initiation (3.10),

3.5 Input Data Buffer

3.5.1 General Characteristics

Analog input samples accumulate in the analog input data FIFO data buffer, which has a capacity of 256K data values. Data accumulates in the buffer until extracted by the PCI bus from a single register location, indicated as INPUT DATA BUFFER in Table 3.1. Reading an empty buffer returns an indeterminate value.

3.5.2 Data Organization

Each value in the data buffer consists of a 5-bit channel tag field, a zero-pad field, and a data field, as shown in Table 3.5.2. The width of the right-justified data field is adjustable from 16 bits to 24 bits by the buffer control register (Table 3.5.3), and the width of the zero-pad field is adjusted accordingly. The zero-pad field becomes a sign-extension field if two's complement data coding is selected.

Table 3.5.2. Input Data Buffer Organization
Offset: 0000 0030h **Default: XXXX XXXXh**

SELECTED DATA WIDTH	RESERVED (Zero)	CHANNEL TAG	ZERO-PAD	CHANNEL DATA VALUE
16 Bits	D[31..29]	D[28..24]	D[23..16]	D[15..0]
18 Bits	D[31..29]	D[28..24]	D[23..18]	D[17..0]
20 Bits	D[31..29]	D[28..24]	D[23..20]	D[19..0]
24 Bits	D[31..29]	D[28..24]	---	D[23..0]

3.5.2.1 Channel Tags

If the input channels are not scan-synchronized (Paragraph 3.10), the order in which channel data accumulates in the buffer is not generally predictable. Therefore, a channel tag that identifies each input channel is attached to associated data values in the buffer.

3.5.2.2 Input Data Format

Input data values can be represented either in offset binary format by asserting the OFFSET BINARY control bit HIGH (default state) in the BCR, or in two's complement format by clearing the control bit LOW. Both coding conventions are illustrated for 16-Bit data in Table 3.5.2.2.

Table 3.5.2.2. Analog Input Data Coding; 16-Bit Data Field

ANALOG INPUT LEVEL	DIGITAL VALUE (Hex)	
	OFFSET BINARY	TWO'S COMPLEMENT
Positive Full Scale minus 1 LSB	FFFFh	7FFFh
Zero plus 1 LSB	8001h	0001h
Zero	8000h	0000h
Zero minus 1 LSB	7FFFh	FFFFh
Negative Full Scale plus 1 LSB	0001h	8001h
Negative Full Scale	0000h	8000h

Positive Full Scale is a positive level that equals the selected input voltage range for the board (e.g.: +5.000 Volts for the ±5V range). *Negative Full Scale* is the negative equivalent of positive full-scale. *Full-scale Range (FSR)* is the total input voltage range. For 16-Bit data, one LSB equals the full-scale range divided by 65,536. (e.g.: 152.59 microvolts for the ±5V range).

3.5.3 Buffer Control Register

The buffer control register (Table 3.5.3) contains the threshold value for the buffer status flag, and also provides control bits for clearing the buffer and for disabling the buffer input.

Table 3.5.3. Buffer Control Register

Offset: 0000 0020h

Default: 0003 FFFEh *

BIT FIELD	MODE	DESIGNATION	FUNCTION
D[17..00]	R/W	BUFFER THRESHOLD	Buffer Flag Threshold
D[18]	R/W	DISABLE BUFFER INPUT	Disables inputs to the data buffer.
D[19]	R/W	CLEAR BUFFER **	Clears (empties) the buffer
D[21..20]	R/W	DATA WIDTH	Controls the width of the buffer data field as: 0 => 16 bits 1 => 18 bits 2 => 20 bits 3 => 24 bits.
D[23..22]	RO	(Reserved)	---
D[24]	R/W	BUFFER OVERFLOW ***	Reports buffer overflow (Write on full)
D[25]	R/W	BUFFER UNDERFLOW ***	Reports buffer underflow (Read on empty)
D[31..26]	RO	(Reserved)	

* Changes to 0103 FFFEh when the buffer fills. ** Clears automatically. *** Clear by writing LOW, or by reset.

NOTE: Since delta-sigma ADC's perform conversions continuously, the initiation and termination of acquisition sequences is controlled by the buffer's 'Clear' and 'Disable' controls.

3.5.3.1 Status Flag and Threshold

The amount of data contained in the input buffer can be used to control the BUFFER THRESHOLD FLAG status bit in the BCR, which can be selected also as an interrupt request event. The interrupt request event can be selected to occur on either the rising or falling edge of the flag (Table 3.8.1).

The threshold flag is asserted HIGH when the number of samples in the buffer **exceeds** the BUFFER THRESHOLD value in the buffer control register. A buffer-empty event is produced when the threshold value is adjusted to equal 0000 0000h and the threshold flag undergoes a HIGH-to-LOW transition.

3.5.3.2 Buffer Clearing and Disabling

Asserting the CLEAR BUFFER control bit in the buffer control register resets (empties) the buffer, and holds the buffer in reset for approximately 10 microseconds to allow the internal data pipeline to empty. This bit clears automatically.

Asserting the DISABLE BUFFER INPUT control bit disables inputs to the buffer from the ADC input channels, and halts the accumulation of further input data. Input data already present in the buffer when this bit is asserted remains in the buffer.

Note: The buffer also can be cleared by writing a "one" to the SOFTWARE SYNC control bit in the BCR when the CLEAR BUFFER ON SYNC control bit is HIGH. See "Global Buffer Clear" in Section 3.10.

3.5.4 Buffer Size Register

This read-only register contains the number of analog input values currently stored in the input data buffer.

3.5.5 Buffer Underflow and Overflow Flags

BUFFER OVERFLOW and BUFFER UNDERFLOW status bits in the buffer control register report overflow (write on full) or underflow (read on empty) events. Once set, these status bits remain HIGH until cleared by writing LOW directly, or by a board reset.

3.6 Input Sampling Control

The local controller establishes the following input sampling parameters:

- a. Sample rate,
- b. Interchannel phase, or skew,
- c. Channel synchronization.

The effective input bandwidth is determined by the sample rate, while phase and synchronization control the relative timing of sampling between multiple channels. Phase and synchronization are considerations in applications that require consistent relative timing of sampling among multiple channels or multiple boards.

Clocking multiple converters from a single sample rate clock prevents the *sampling drift* that occurs when converters are clocked from different sources. *Synchronization* causes the converters in all channels to initiate conversions simultaneously, and can be used to eliminate *sampling skew* between channels.

3.6.1 Sample Rate Control

3.6.1.1 Rate Clock Organization

Sample rates are derived from two internal, independent rate generators, or from a single external hardware clock, as shown in Figure 3.6.1.1. All available input channels are divided equally into two sample groups, and the sample rates for all channels are controlled by the following operations:

- a. Assignment of each group to an internal rate generator or to the external clock,
- b. Rate generator frequency selection,
- c. Rate divisor selection.

The number of channels per group is reduced to four channels for 8-channel boards, or to two channels for 4-Channel boards. This scheme ensures that the board is divided into two equal channel groups, regardless of the number of channels present.

3.6.1.2 Rate Generator Assignment

A 4-bit code RATE SOURCE in the Rate Assignments register selects either an internal rate generator or the external sample rate clock as sample rate source. Group selection codes are arranged in the register as shown in Table 3.6.1.2-1, and use the assignment codes listed in Table 3.6.1.2-2. Channels in a group with a rate assignment of "none" are disabled and do not provide data to the input data buffer.

Note: If scan-synchronization is selected (Section 3.10), the ADC's in all channels are automatically clocked by the Channel-00 ADC clock.

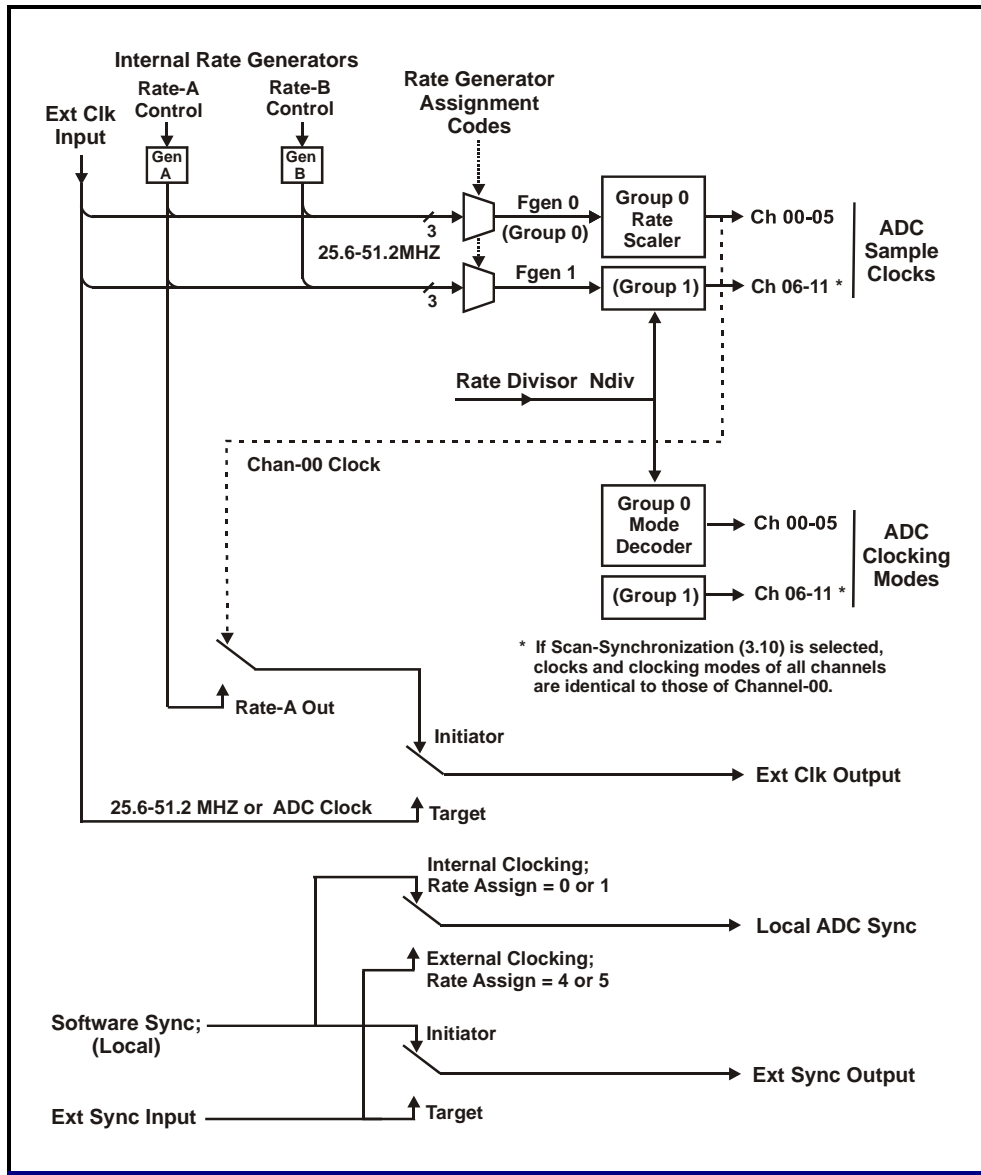

Figure 3.6.1.1. ADC Clock and Sync Organization, 12 Channels

Table 3.6.1.1. Channel Groups

CHANNEL GROUP	12-CHAN BOARD	8-CHAN BOARD	4-CHAN BOARD
0	Channels 00-05	00-03	00, 01
1	Channels 06-11	04-07	02, 03

Table 3.6.1.2-1. Rate Assignments Register

Offset: 0000 000Ch

Default: 0000 0000h

BIT FIELD	DESIGNATION	CHANNEL GROUP
D[03..00]	GROUP 0 RATE SOURCE	0
D[07..04]	GROUP 1 RATE SOURCE	1
D[31..07]	(Reserved)	---

Table 3.6.1.2-2. Rate Generator Assignment Codes

ASSIGNMENT CODE	RATE CLOCK SOURCE
0	Rate Generator-A
1	Rate Generator-B
2	(Reserved)
3	(Reserved)
4	External Sample Clock (as Rate-A generator input)
5	Direct External Sample Clock (routed directly to ADC)
6-7	None (Disabled)
8-15	(Reserved)

3.6.1.3 Sample Clock Generation

A rate divisor integer **Ndiv** controls a *rate divisor* for the rate generator or external clock input. Rate divisors are arranged in the Rate Divisor register as shown in Table 3.6.1.3.

Table 3.6.1.3. Rate Divisor Register

Offset: 0000 0010h

Default: 0000 0505h

BIT FIELD:	GROUP DIVISOR
D[07..00]	RATE DIVISOR 0 (Ndiv): 0 - 25
D[15..08]	RATE DIVISOR 1 (Ndiv): 0 - 25
D[31..16]	(Reserved)

The ADC sample rate **F_{samp}** is determined by the rate generator frequency **F_{gen}** and a rate **DIVISOR** as: (all values in decimal)

$$\mathbf{F_{samp} = F_{gen} / (512 * DIVISOR),} \quad \mathbf{(3-1)}$$

where **F_{samp}** and **F_{gen}** are in kilohertz, and **DIVISOR** is defined as:

$$\begin{aligned} \mathbf{If\ Ndiv > 0, \ then\ DIVISOR = Ndiv,} \\ \mathbf{If\ Ndiv = 0, \ then\ DIVISOR = 0.5,} \end{aligned}$$

where **Ndiv** can have any integer value from zero through 25, and **F_{gen}** has a range of 25.6 MHz through 51.2 MHz.

If the clock source is an internal rate generator, **F_{gen}** is determined by **Nrate** as described in Paragraph 3.6.1.4. If the source is the external clock input, then **F_{gen}** equals the frequency of the external clock.

Note: The ADC's operate in one of three different clocking modes, with each mode determined by the assigned sample rate. In addition to establishing the sample rate division factor **DIVISOR**, the integer **Ndiv** also controls the ADC clocking mode.

3.6.1.4 Rate Generator Control

Each of the internal Rate-A and Rate-B generators is a PLL-controlled oscillator locked to a stable reference frequency. Older (Legacy) versions of this product implement a high-resolution generator that could be adjusted with 10PPM resolution. The PLL configuration however provides less clock jitter, and consequently produces a more finely detailed spectrum and a lower noise floor. The frequencies of the generators are controlled by the Rate Control A and Rate Control B registers listed in Table 3.1. The effect of these registers is determined by the specific PLL or Legacy rate generator option that is present on the board, which is specified in the Board Configuration register (Table 3.11.1).

3.6.1.4.1 PLL Rate Generators

If the PLL Rate Generator ordering option applies, **F_{gen}** is generated by an internal phase-locked loop (PLL) oscillator. The frequency **F_{gen}** of the oscillator is related to a reference frequency **F_{ref}** by integers **Nvco** and **Nref** (Table 3.6.1.4-1) as:

$$\mathbf{F_{gen} = F_{ref} * \frac{N_{vco}}{N_{ref}},} \quad \mathbf{(3-2)}$$

where **Nvco** and **Nref** each has a maximum range from 30 to 1000, and **F_{ref}** is the frequency of the reference oscillator, which has a standard frequency of **32.768MHz**. Table 3.6.1.4-3 is a summary of sample rate control parameters.

*Because specific applications might require custom values for **F_{ref}**, an approximate measurement of the installed PLL reference oscillator frequency is available in the PLL Reference Freq register listed in Table 3.1. This value is determined at initialization, and equals **F_{ref}** in Hertz with an accuracy of approximately 0.02-percent. It is intended as an indicator only, and is not recommended as a source for the actual **F_{ref}** frequency.*

NOTE: *Nvco* and *Nref* each has a maximum range from 30 to 1000. For optimum performance, select the *lowest* possible values for *Nvco* and *Nref*.

By combining Equation 3-2 with Equation 3-1 in Section 3.6.1.3:

$$\frac{Nvco}{Nref} = \frac{Fsamp * 512 * DIVISOR}{Fref (32.768MHz)} \quad (3-3)$$

Table 3.6.1.4-1. PLL Rate Control Registers

Offset: Rate-A: 0004h, Rate-B: 0008h

Default: 0040 0032h *

BIT FIELD	MODE	DESIGNATION	FUNCTION
D[09..00]	R/W	VCO FACTOR (Nvco)	PLL VCO factor; 30-1000.
D[15..10]	R/W	(Reserved)	---
D[25..16]	R/W	REF FACTOR (Nref)	PLL Reference factor; 30-1000.
D[31..27]	R/W	(Reserved)	---

* Both rate generators default to 25.6MHz.

Table 3.6.1.4-2. Summary of PLL Sample Rate Control Parameters

PARAMETER	NOTATION	RANGE
VCO Factor	Nvco	30-1000
Reference Factor	Nref	30-1000
Rate Divisor	Ndiv	0 - 25
Reference Frequency	Fref	Standard value = 32.768MHz

The following examples illustrates one of several methods for determining **Nvco** and **Nref**: (Calculating the optimum values for integers **Nvco** and **Nref** can often be simplified by converting all variables, including **Fref**, into products of their prime factors):

EXAMPLE: Required sample rate **Fsamp** is 15.360 kHz. **Fref** = 32.768 MHz:

1. Insert the **Fref** and required **Fsamp** values into Equation 3-3, expressing both in Hertz.

$$\frac{Nvco}{Nref} = \frac{15360 * 512 * DIVISOR}{32768000}$$

2. Convert **Fref** and **Fsamp** into their prime factors, and simplify the fraction by canceling all factors that are duplicated in the numerator and denominator

$$\frac{Nvco}{Nref} = \frac{(2^{10} * 3 * 5) * (2^9) * DIVISOR}{2^{18} * 5^3} = \frac{6 * DIVISOR}{25}$$

3. Select a value for **DIVISOR** that adjusts the value of the fraction to between 0.78 and 1.56 (25.6MHz to 51.2MHz /32.768MHz), with unity being ideal. In this case, use **DIVISOR = 4**:

$$\frac{N_{vco}}{N_{ref}} = \frac{24}{25}$$

4. Multiply both numerator and denominator by an integer that produces the lowest possible in-range values for **Nvco** and **Nref**, which must be 30 or greater. In this case, multiply by 2:

$$\frac{N_{vco}}{N_{ref}} = \frac{48}{50}$$

5. Final Results: **Nvco = 48; Nref = 50; DIVISOR = 4.**

To confirm the results, first use Equation 3-2 to verify that the rate generator frequency **Fgen** is within the specified range of 25.6 - 51.2 MHz. If **Fgen** is out of range, select another **DIVISOR** value in Step-3:

$$\begin{aligned} F_{gen} &= F_{ref} * \frac{N_{vco}}{N_{ref}} \\ &= 32,768,000 \text{ Hz} * \frac{48}{50} = \underline{31,457,280 \text{ Hz}}. \end{aligned}$$

Finally, use Equation 3-1 to verify the sample rate **Fsamp**:

$$\begin{aligned} F_{samp} &= \frac{F_{gen}}{512 * \text{DIVISOR}} \\ &= \frac{31,457,280 \text{ Hz}}{512 * 4} = \underline{15,360 \text{ Hz}} . \end{aligned}$$

3.6.1.4.2 Legacy Rate Generators

For boards equipped with the Legacy Rate Generator option, the frequency **Fgen** of an internal rate generator is controlled by a variable **Nrate** (Table 3.6.1.4-2) as:

$$\boxed{F_{gen} = 25.6 * (1 + N_{rate}/100,000),} \tag{3-4}$$

where **Fgen** is in Megahertz, and **Nrate** has a range from zero through 100,000.

Table 3.6.1.4-3. Legacy Rate Control Registers

Offset: Rate-A: 0004h, Rate-B: 0008h

Default: 0000 0000h *

BIT FIELD	MODE	DESIGNATION	FUNCTION
D[16..00]	R/W	RATE CONTROL (Nrate)	Frequency control factor; 0-100,000
D[31..17]	R/W	(Reserved)	---

* Both rate generators default to 25.6MHz.

Determining the optimum values for **Nrate** and **Ndiv** is usually an iterative process that starts by selecting a maximum value for **DIVISOR** (from **Ndiv**) in Equation 3-1, and then selects successively smaller values of **Ndiv** until valid values for both **Ndiv** and **Nrate** produce a value for **Fsamp** that is as close as possible to the required value.

3.6.1.5 Direct External Clocking

If the rate assignment selection (Table 3.6.1.2-2) is "Direct External Sample Clock," the signal at the external clock input is routed directly to the ADC's without modification. This configuration eliminates the effects of the Rate Control registers, and gives the external clock source direct control of the ADC's.

Although the Rate Control A/B registers and the Rate Divisor register (**Ndiv**) have no effect on the clocking frequency in this configuration, the **clocking mode** of the ADC's must be controlled by **Ndiv** as shown in Figure 3.6.1.1. Table 3.6.1.6 shows the relationships between the sample rate **Fsamp**, the external clock frequency, and the required values for **Ndiv**.

Table 3.6.1.5. Direct External Clocking

Sample Rate Fsamp (KSPS)	External Clock Frequency	Divisor Integer Ndiv
2-50	256 * Fsamp	2 thru 25
50-100	128 * Fsamp	1
100-200	64 * Fsamp	0

3.6.1.6 Harmonically Locked Channels

Channel groups operating at different frequencies that are exact submultiples of a common frequency perform conversions repetitively, relative to a sampling frame, and are *harmonically locked*. An example of this might be two groups operating from the same Fgen source at 25.6 MHz, with Ndiv values of 2 and 8. Using Equation 3-1 in Paragraph 3.6.1.3, the corresponding sample rates for the four groups would be 25 KSPS and 6.25 KSPS, respectively.

3.6.2 Channel Synchronization

Due to the oversampling nature of delta-sigma conversion, each conversion represents a sampling interval consisting of multiple clock cycles, and simply operating all converters from a common clock does not ensure simultaneous, or skew-free, sampling. To ensure simultaneous sampling, the converters must be synchronized to perform conversions simultaneously relative to a common point in time. Thereafter, the converters will continue to sample simultaneously while operating from a common clock.

Synchronization is invoked by **clearing** the ASYNCHRONOUS SYNC control bit **LOW** in the BCR. This is the default state after initialization. Completion of the synchronization sequence is indicated by the CHANNELS READY flag in the BCR undergoing a Low-to-High transition (Paragraph 3.4.3). The CHANNELS READY transition can be selected as a condition for an interrupt request event.

3.6.3 Multiboard Operation

Multiple PMC-24DSI12 boards can be connected together to share a common sampling clock and synchronization command. One of the boards is designated as the *initiator*, and the remaining boards are designated as *targets*. A board is designated as an initiator by setting the INITIATOR control bit HIGH in the BCR, or as a target when the control bit is LOW. *The INITIATOR control bit controls only the sources of the external clock and sync outputs, and has no other effect.*

The TTL EXTERNAL SYNC I/O control bit in the BCR selects single-ended TTL logic levels for the external clock and sync I/O signal when HIGH, or differential LVDS logic when LOW.

3.6.3.1 External Sample Clock

Target boards receive an external clock from the external clock input connection, and duplicate the input clock at the external clock output connection (Figure 3.6.1.1). The external clock input is designated as the clocking source by writing either the "External Sample Clock" or "Direct External Sample Clock" assignment code to the target boards' Rate Assignments register described in Paragraph 3.6.1.2. For calculation of target board sample rates, the external sample clock corresponds to the rate generator frequency **Fgen** described in Section 3.6.1 if "External Sample Clock" is selected, or provides the ADC sample clock directly if "Direct External Sample Clock" is selected.

An **initiator** provides an external clock output from either of two sources. If the RATE GEN EXT CLOCK OUT control bit in the BCR is LOW (default), the external clock output is identical to the Group 00 ADC sample clock, which equals the internal rate generator output divided by the rate divisor. If the control bit is HIGH, the rate generator unmodified output provides the external clock.

NOTE: The INITIATOR control bit controls only the sources of the external clock and sync output signals, and has no other effect.

Multiple boards can all be configured as initiators and operated in a "star" configuration to operate from a single rate generator. To avoid overloading the LVDS source driver, an LVDS distribution module usually is required in this configuration.

3.6.3.2 External Sync

Boards that are hardware-configured for multiboard synchronization initiate a *synchronization sequence* each time a sync pulse is generated by the initiator board.

The SOFTWARE SYNC control bit in the BCR can be used also to clear the buffers on the initiator and target boards simultaneously, by first setting the CLEAR BUFFER ON SYNC control bit HIGH in the BCR.

3.7 Autocalibration

Autocalibration is an embedded utility that calibrates all input channels to a single internal voltage reference. Offset and gain error corrections for each channel are determined during autocalibration, and are applied to each channel in real-time during data acquisition. The correction values are retained until either: (a) power is removed, (b) a PCI reset occurs, or (c) autocalibration is invoked again. Autocalibration is invoked by setting the AUTOCAL control bit HIGH in the BCR. Completion of autocalibration is indicated by the AUTOCAL flag clearing automatically to the LOW state. Clearing of the AUTOCAL control bit is selectable as an interrupt request event.

An autocalibration sequence has a typical duration from 2 to 5 seconds, depending upon the selected sample rate and number of active channels. Read or write access from the PCI bus during autocalibration may disrupt the calibration process, and should be avoided. Either a suitable delay or the "Autocal Completed" interrupt should be used to detect the end of autocalibration.

If a board is defective, the autocalibration process may be unable to successfully calibrate all input channels. If this situation occurs, the AUTOCAL PASS status flag in the BCR will be LOW when the autocal sequence is completed. A HIGH state for AUTOCAL PASS indicates that autocalibration was successful.

To ensure full conformance to the product specification, autocalibration should always be invoked after:

- (a). Power has been applied to the board,
- (b). A PCI reset event has occurred,
- (c). The input range, clock source or sampling rate has been altered,
- (d). A scan-synchronization sequence has been performed (Section 3.10).

Autocalibration can be invoked at any time, but should not occur while the system is experiencing a major environmental transition such as that which usually occurs directly after power is applied. For optimum performance, a warmup delay of 15 minutes is recommended.

3.8 Interrupt Control

In order for the board to generate a PCI interrupt on INTA#, *both* of the following conditions must occur:

- a. The internal controller must generate a Local Interrupt Request
- b. The *PCI interrupt* must be enabled.

If the internal controller generates a local interrupt request, a PCI bus interrupt will not occur unless the PCI interrupt has been enabled as described below in Paragraph 3.8.2.

3.8.1 Local Interrupt Request

The single local interrupt request line is controlled by the INTERRUPT A[2:0] and INTERRUPT REQUEST FLAG control bits in the BCR. The condition for the interrupt request is selected as shown in Table 3.8.1. When the selected condition occurs, a local interrupt request is generated and the INTERRUPT REQUEST FLAG bit is set in the BCR. The request remains asserted until the PCI bus clears the BCR request flag. A local interrupt request is generated automatically at the end of initialization.

Detection of an interrupt condition or event is *edge-sensitive*. An interrupt request is generated if, and only if, a specific interrupt condition undergoes a *transition* from 'false' (not-true) to 'true' while that condition is selected.

Table 3.8.1. Interrupt Event Selection

INTERRUPT A[2:0]	INTERRUPT EVENT CONDITION
0	Initialization completed. Default state.
1	Autocal completed
2	Channels Ready
3	Data Buffer threshold flag, LOW-to-HIGH transition
4	Data Buffer threshold flag, HIGH-to-LOW transition
5	(Reserved)
6	(Reserved)
7	(Reserved)

3.8.2 Enabling the PCI Interrupt

A local interrupt request will not produce an interrupt on the PCI bus unless the PCI interrupt is enabled. The PCI interrupt is enabled by setting the *PCI Interrupt Enable* and *PCI Local Interrupt Enable* control bits HIGH in the runtime *Interrupt Control/Status Register* described in Section 4 of the PLX™ PCI-9080 reference manual..

3.9 DMA Operation

DMA transfers from the analog input buffer are supported in either of two DMA channels with the board operating as bus master. Table 3.9.1 illustrates a typical PCI register configuration that controls a non-chaining, non-incrementing '**block-mode**' Channel-0 DMA transfer, in which a PCI interrupt is generated when the transfer has been completed. Bit 02 (0000 0004h) in the PCI Command register must be set HIGH to select the bus mastering mode. Refer to a PCI-9080 reference manual for a detailed description of these registers.

Table 3.9.1. Typical DMA Register Configuration; DMA Channel-0

PCI Offset	PCI Register	Function	Typical Value
80h	DMA Mode	Bus width (32); Interrupt on done	0002 0D43h
84h	DMA PCI Address	Initial PCI data source address	*
88h	DMA Local Address	Analog Input Buffer local address (Analog input buffer)	0000 0030h
8Ch	DMA Transfer Byte Count	Number of bytes in transfer	*
90h	DMA Descriptor Counter	Transfer direction; Local bus to PCI bus (Analog inputs)	0000 000Ah
A8h	DMA Command Status	Command and Status Register	0000 0001h 0000 0003h (See Text)

* Determined by specific transfer requirements.

For most applications, the DMA Command Status register would be initialized to the value 0000 0001h, and then changed to 0000 0003h to initiate a transfer.

Bit-12 (0000 1000h) in the Channel-0 DMA Mode configuration register, when HIGH, selects '**demand-mode**' DMA operation, in which a DMA transfer is requested automatically when the number of values in the buffer **exceeds the selected buffer threshold** (Table 3.5.3).

The DMA request is sustained until one of the following events occurs:

- (a) The data buffer goes empty,
- (b) The number of values read from the buffer equals the threshold value *plus one*,
- (c) The buffer is cleared,
- (d) The board is reset,
- (e) Autocalibration is executed.

The first occurrence of any of these events terminates the DMA request.

3.10 Scan Synchronization

Although the data sequence for any specific channel in the data buffer represents the actual sampling sequence for that channel, the ordering of multiple channels in the buffer can vary due to the asynchronous nature of the sample clock relative to the board's master clock. These variations in channel order can occur even though all channels are synchronized to a common sample clock.

Variations in the ordering of multiple channels can be eliminated by synchronizing the acquisition of each scan to the board's master clock. This **scan-synchronization** can be effective only if all active channels are operating from a common clock source.

Note: References to *channel synchronization* in this manual pertain to the situation in which the sampling of all input channels occurs simultaneously. *Scan-synchronization* refers to the synchronization of discrete data scans to the master clock, to ensure a consistent ordering of data channels in the data buffer.

For synchronized scans, the channel sequence for each scan in the buffer is ordered from lowest to highest. All samples in each scan represent the same sample event, and are arranged beginning with the lowest active channel and proceeding upward through the highest active channel. Table 3.10.1 illustrates examples of channel sequences in both synchronized and nonsynchronized scans in which eight channels are active. Scan synchronization is invoked by clearing the ASYNCHRONOUS SCAN control bit LOW in the BCR.

Table 3.10.1. Channel Order (Active channels 00-07)

SAMPLE EVENT	CHANNEL ORDER	
	NON-SYNCHRONIZED SCANS (Typical)	SYNCHRONIZED SCANS
T _n	34567012	01234567
T _{n+1}	56701234	01234567
T _{n+2}	01234567	01234567
T _{n+3}	45670123	01234567
T _{n+4}	12345670	01234567

Synchronous scanning is the default condition after a board reset. To disable synchronous scanning, set the ASYNCHRONOUS SCAN control bit HIGH in the BCR.

To enable synchronous scanning, set then clear the ASYNCHRONOUS SCAN control bit in the BCR, and wait for the CHANNELS READY flag (3.4.3) in the BCR to undergo a LOW-to-HIGH transition. While the CHANNELS READY flag is LOW, the following sequence is executed by the local controller:

1. The Group-0 sample clock (Section 3.6.1) is distributed to all input channels,
2. All ADC's are channel-synchronized (Section 3.6.2),
3. All channels are scan-synchronized.

The buffer clears to empty, and the first two scans are discarded to ensure full synchronization. Subsequent samples are scan-synchronized as described above. The Channels-Ready flag can be used to generate an interrupt at the end of the process.

Notice that all enabled input channels receive the sample clock selected for Group-0 *while operating in the scan-synchronized mode*, and the sample clock settings for Group-1 are ignored. Disabled groups remain disabled.

Use the following sequence to enable synchronous scanning of multiple boards (Paragraph 3.6.3)

Synchronize ADC's:

1. On all boards: Set, then clear ASYNCHRONOUS SCAN;
Wait for Channels Ready LOW-to-HIGH on all boards (LOW 1-100ms).
(Sampling is synchronized on each board, but sample-skewed between boards)
2. On Initiator: Set SOFTWARE SYNC;
Wait for Channels Ready LOW-to-HIGH on all boards (LOW 1-100ms).
(All ADC's are scan synchronized; but data in the buffers is still skewed)

Global Buffer Clear:

3. On all boards: Set the CLEAR BUFFER ON SYNC bit,
4. On Initiator: Set SOFTWARE SYNC;
Wait for Channels Ready LOW-to-HIGH on the initiator. (LOW 10us to 5ms),
(All ADC's and buffers are scan-synchronized)
5. On all boards: Clear the CLEAR BUFFER ON SYNC bit.

For optimum DC performance, execute autocalibration on all boards after synchronizing the ADC's on all boards, and follow the procedure with a 'global clear' operation.

NOTE: If autocalibration is executed while scan-synchronized, repeat the global buffer clear sequence (Steps 3 through 5). To simplify this operation, the CLEAR BUFFER ON SYNC control bit can remain HIGH while scan-synchronized.

3.11 Board Configuration Register

The read-only board configuration register (Table 3.11.1) contains the existing firmware revision and a status field that indicates the availability of optional features.

Table 3.11.1. Board Configuration Register
Offset: 0000 0024h **Default: 000X XXXXh**

BIT FIELD	DESCRIPTION
D00-D11	Firmware Revision
D12-D14	(Reserved status flags).
D15	High if PLL Rate generators are present; Low for Legacy generators.
D16	High if only 8 input channels are present.
D17	High if only 4 input channels are present.
D18	High if the board contains custom filter frequencies.
D19	High if configured for extended-temperature operation.
D20-D31	(Reserved)

SECTION 4.0

PRINCIPLES OF OPERATION

4.1 General Description

The PMC-24DSI12 board contains six dual delta-sigma 24-Bit A/D converters and all supporting functions necessary for adding analog I/O capability to a PMC site. A PCI interface adapter (Figure 4.1) provides the interface between the controlling PCI bus and an internal local controller through a 32-bit local bus. The local controller performs all internal configuration and data manipulation functions, including autocalibration.

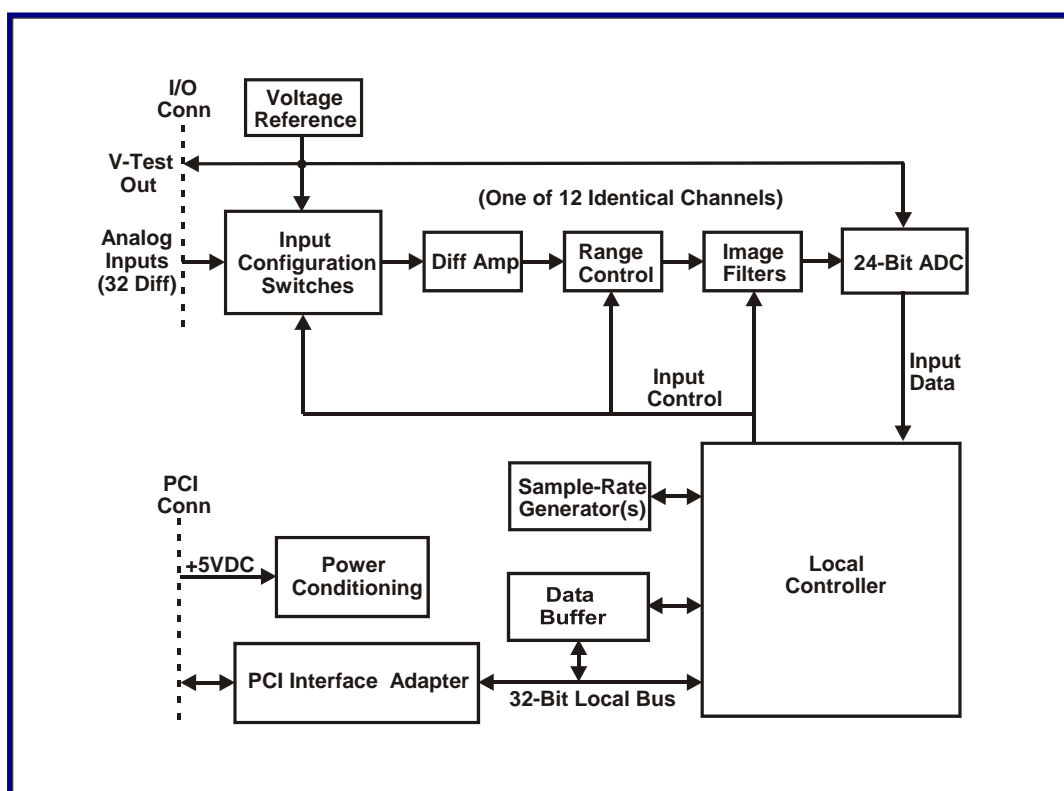

Figure 4.1. Functional Block Diagram

Input configuration switches allow the controller to select any of several signal sources as inputs to the ADC's. This feature is used to establish the internal connections necessary during autocalibration, and also permits verification from the PCI bus of the integrity of all analog input channels. All channels are calibrated against a single precision voltage reference. The offset and gain calibration of each input channel is adjusted with correction values that are determined during autocalibration.

4.2 Analog Inputs

The 12 analog input channels are arranged in two channel groups, with each group containing one-half of the channels present on the board. Either group can be designated as either active or inactive, with only active groups sending input data to the data buffer. Analog-to-digital conversions can be performed on signals from any of several sources, which are selected by the input configuration switches shown in Figure 4.1. During normal operation, the analog input signal passes through a differential amplifier which removes any common mode voltage that might be present. During selftest and autocalibration operations, the input configuration switches can be used to replace the system input signal with either a precision zero (ground) or positive full-scale reference voltage.

A range control attenuator adjusts the maximum level of the signal to the full-scale input range of 2.0 VRMS required by the ADC. High frequency noise and digital filter images are attenuated by a 2-pole Butterworth lowpass filter, the cutoff frequency of which can be selected from either of two fixed frequencies.

The final conditioned, scaled and filtered input signal is digitized by each ADC into a 24-Bit serial data word that is deserialized into parallel format by the local controller. The local controller then attaches a 5-bit channel tag to the data word, applies offset and gain corrections, and finally transfers the corrected data to the input data buffer.

Antialias filtering is provided by each ADC in the form of a lowpass digital filter with a sharp cutoff frequency at approximately 40-50 percent of the sampling frequency. The digital filter has no filtering effect at multiples of the sampling clock, which is a multiple (x32-128) of the sampling frequency. To prevent extraneous signal frequency components within these "filter images" from appearing in the passband, the hardware image filters shown in Figure 4.1 can be configured to provide filtering within the digital filter images.

4.3 Autocalibration

Autocalibration is an embedded firmware utility that calibrates all input channels to a single internal voltage reference. Application software can invoke the utility at any time.

The offset error of each channel is determined first, by selecting a zero input reference level and storing the values reported from all channels. A precision internal voltage reference then is used to calculate the gain error, and both offset and gain correction values are stored in internal RAM for retrieval during data acquisition.

The internal voltage reference is adjusted to equal 99.00 percent of the selected input voltage range. This in-range value ensures that the ADC's will provide the nonsaturated, or in-range, responses that are necessary during the calibration adjustment process.

4.4 Sampling Clocks

Each of two internal sample rate generators provides a frequency range of 25.6 - 51.2 MHz, which is divided down by a software-specified integers to provide sample rates from 2.0 KSPS to 200 KSPS. Either generator can be assigned to either channel group.

An external clock output can be assigned as the output of the rate generator, or as the ADC sample clock. A board from which a rate generator or ADC sample clock originates is a *clock initiator*. Boards that receive and retransmit the external clock are *clock targets*. Multiple targets can be controlled from a single initiator.

4.5 Power Control

Regulated supply voltages of +5 Volts, +6 Volts and ± 14 Volts are required by the internal analog networks. Multiple DC/DC converters in the power conditioner use +5V input power from the PCI bus to produce preregulated DC voltages that subsequently are postregulated with linear regulators to the required supply voltages. Linear regulators ensure that the final power voltages delivered to the analog networks are well-regulated and free of noise.

APPENDIX A

LOCAL REGISTER QUICK REFERENCE

APPENDIX A

LOCAL REGISTER QUICK REFERENCE

This appendix summarizes all local registers in the order in which they appear in Section 3.

Table 3.1. Control and Data Registers

LOCAL ADDR	ACCESS MODE *	REGISTER	DEFAULT	DESCRIPTION
00	R/W	Board Control (BCR)	0000 383Ch *	Board Control Register (BCR)
04	R/W	Rate Control A	0040 0032h	Rate Generator-A control
08	R/W	Rate Control B	0040 0032h	Rate Generator-B control.
0C	R/W	Rate Assignments	0000 0000h	Channel-group rate generator assignment
10	R/W	Rate Divisors	0000 0505h	Channel-group sample rate divisors.
14	RO	(Reserved)	0000 0000h	---
18	RO	PLL Reference Freq	XXXX XXXXh	PLL reference frequency indicator.
1C	RO	(Reserved)	0000 0000h	---
20	R/W	Buffer Control	0003 FFFEh **	Input buffer control and status
24	RO	Board Configuration	00XX XXXXh	Installed firmware and hardware options
28	RO	Buffer Size	0XXX XXXXh	Number of ADC values in the input buffer.
2C	RO	Autocal Values ***	---	---
30	RO (DMA)	Input Data Buffer	XXXX XXXXh	Input Data Buffer; Data and channel tag
34-7C	--	(Reserved)	---	---

* Changes to 0000 783Ch when the input buffer fills.

** Changes to 0103 FFFEh when the buffer fills.

R/W = Read/Write; RO = Read-Only.

*** Maintenance register; Shown for reference only.

Table 3.2. Board Control Register

Offset: 0000h

Default: 0000 383Ch **

DATA BIT	MODE	DESIGNATION	DESCRIPTION	SECTION
D00	R/W	AIM0	Analog input mode. Selects system inputs or selftest mode. Defaults to system inputs.	3.4
D01	R/W	AIM1		
D02	R/W	RANGE0	Analog input range selection. Defaults to $\pm 10V$ range.	3.4.2
D03	R/W	RANGE1		
D04	R/W	OFFSET BINARY	Selects offset binary or two's complement input data format. Defaults HIGH to offset binary.	3.5.2.2
D05	R/W	INITIATOR	Selects INITIATOR or TARGET mode for external clock and sync signals. Defaults to Initiator mode.	3.6.3
D06	R/W	*SOFTWARE SYNC	Initiates a local ADC sync operation when asserted. Also generates an external sync output if INITIATOR mode is selected. Clears automatically.	3.6.3.2
D07	R/W	*AUTOCAL	Initiates an autocalibration operation when asserted. Clears automatically upon completion.	3.7
D08	R/W	INTERRUPT A0	Interrupt event selection. Default is zero. Set HIGH when the board requests an interrupt. Clears the request when cleared LOW by the bus.	3.8.1
D09	R/W	INTERRUPT A1		
D10	R/W	INTERRUPT A2		
D11	R/W	INTERRUPT REQUEST FLAG		
D12	RO	AUTOCAL PASS	Set HIGH at reset or autocal initialization. Cleared LOW if autocalibration terminates unsuccessfully.	3.7
D13	RO	CHANNELS READY	LOW during any change in channel parameters. Asserted HIGH when ADC clocks are stabilized.	3.4.3
D14	RO	BUFFER THRESHOLD FLAG	Asserted HIGH when buffer contents exceed the assigned threshold.	3.5.3.1
D15	R/W	*INITIALIZE	Initializes the board when asserted.	3.3.2
D16	R/W	ASYNCHRONOUS SCAN	Disables synchronous sampling mode when HIGH .	3.10
D17	R/W	CLEAR BUFFER ON SYNC	Changes the context of the SOFTWARE SYNC control bit changes to CLEAR BUFFER.	3.5.3.2
D18	R/W	RATE-A EXT CLOCK OUT (Initiator Mode only)	When HIGH: Selects the Rate-A generator as the external clock output source. When LOW: Selects the Group-00 sample clock as the output. (If Group-00 external clocking is selected, the output is driven by the Rate-A generator and the Group-00 divisor).	3.6.3.1
D19	R/W	LOW FREQ FILTER	Selects the low-frequency image filter when HIGH, or the high-frequency filter when LOW.	3.4
D20	R/W	TTL EXTERNAL SYNC I/O	Selects TTL external sync I/O configuration.	3.6.3
D21-31	RO	(Reserved)	---	---

* Cleared automatically.

R/W = Read/Write; RO = Read-Only.

** Changes to 0000 783Ch when the input buffer fills.

Table 3.3.1. Configuration Operations

Operation	Maximum Duration
PCI configuration registers are loaded from internal EEPROM	3 ms
Internal control logic is configured from internal ROM	300 ms
Internal control logic is initialized	3 ms
Rate generator clocks are initialized	250 ms

Table 3.4. Analog Input Function Selection

AIM[..0]	FUNCTION OR MODE
0	Differential analog input mode.
1	(Reserved).
2	ZERO test. Internal ground reference is connected to all analog input channels.
3	+VREF test. Internal voltage reference is connected to all analog input channels.

Table 3.4.3. Analog Input Range Selection

RANGE[1..0]	ANALOG INPUT RANGE
0	±2.5 Volts
1	±2.5 Volts
2	±5 Volts
3	±10 Volts

Table 3.5.2. Input Data Buffer Organization

Offset: 0000 0030h

Default: XXXX XXXXh

SELECTED DATA WIDTH	RESERVED (Zero)	CHANNEL TAG	ZERO-PAD	CHANNEL DATA VALUE
16 Bits	D[31..29]	D[28..24]	D[23..16]	D[15..0]
18 Bits	D[31..29]	D[28..24]	D[23..18]	D[17..0]
20 Bits	D[31..29]	D[28..24]	D[23..20]	D[19..0]
24 Bits	D[31..29]	D[28..24]	---	D[23..0]

Table 3.5.2.2. Analog Input Data Coding; 16-Bit Data Field

ANALOG INPUT LEVEL	DIGITAL VALUE (Hex)	
	OFFSET BINARY	TWO'S COMPLEMENT
Positive Full Scale minus 1 LSB	FFFFh	7FFFh
Zero plus 1 LSB	8001h	0001h
Zero	8000h	0000h
Zero minus 1 LSB	7FFFh	FFFFh
Negative Full Scale plus 1 LSB	0001h	8001h
Negative Full Scale	0000h	8000h

Table 3.5.3. Buffer Control Register

Offset: 0000 0020h

Default: 0003 FFFEh *

BIT FIELD	MODE	DESIGNATION	FUNCTION
D[17..00]	R/W	BUFFER THRESHOLD	Buffer Flag Threshold
D[18]	R/W	DISABLE BUFFER INPUT	Disables inputs to the data buffer.
D[19]	R/W	CLEAR BUFFER **	Clears (empties) the buffer
D[21..20]	R/W	DATA WIDTH	Controls the width of the buffer data field as: 0 => 16 bits 1 => 18 bits 2 => 20 bits 3 => 24 bits.
D[23..22]	RO	(Reserved)	---
D[24]	R/W	BUFFER OVERFLOW ***	Reports buffer overflow (Write on full)
D[25]	R/W	BUFFER UNDERFLOW ***	Reports buffer underflow (Read on empty)
D[31..26]	RO	(Reserved)	

* Changes to 0103 FFFEh when the buffer fills. ** Clears automatically. *** Clear by writing LOW, or by reset.

Table 3.6.1.1. Channel Groups

CHANNEL GROUP	12-CHAN BOARD	8-CHAN BOARD	4-CHAN BOARD
0	Channels 00-05	00-03	00, 01
1	Channels 06-11	04-07	02, 03

Table 3.6.1.2-1. Rate Assignments Register

Offset: 0000 000Ch

Default: 0000 0000h

BIT FIELD	DESIGNATION	CHANNEL GROUP
D[03..00]	GROUP 0 RATE SOURCE	0
D[07..04]	GROUP 1 RATE SOURCE	1
D[31..07]	(Reserved)	---

Table 3.6.1.2-2. Rate Generator Assignment Codes

ASSIGNMENT CODE	RATE CLOCK SOURCE
0	Rate Generator-A
1	Rate Generator-B
2	(Reserved)
3	(Reserved)
4	External Sample Clock (as Rate-A generator input)
5	Direct External Sample Clock (routed directly to ADC)
6-7	None (Disabled)
8-15	(Reserved)

Table 3.6.1.3. Rate Divisor Register

Offset: 0000 0010h

Default: 0000 0505h

BIT FIELD:	GROUP DIVISOR
D[07..00]	RATE DIVISOR 0 (Ndiv): 0 - 25
D[15..08]	RATE DIVISOR 1 (Ndiv): 0 - 25
D[31..16]	(Reserved)

Table 3.6.1.4-1. PLL Rate Control Registers

Offset: Rate-A: 0004h, Rate-B: 0008h

Default: 0040 0032h *

BIT FIELD	MODE	DESIGNATION	FUNCTION
D[09..00]	R/W	VCO FACTOR (Nvco)	PLL VCO factor; 30-1000.
D[15..10]	R/W	(Reserved)	---
D[25..16]	R/W	REF FACTOR (Nref)	PLL Reference factor; 30-1000.
D[31..27]	R/W	(Reserved)	---

* Both rate generators default to 25.6MHz.

Table 3.6.1.4-3. Summary of PLL Sample Rate Control Parameters

PARAMETER	NOTATION	RANGE
VCO Factor	Nvco	30-1000
Reference Factor	Nref	30-1000
Rate Divisor	Ndiv	0 - 25
Reference Frequency	Fref	Standard value = 32.768MHz

Table 3.6.1.4-2. Legacy Rate Control Registers

Offset: Rate-A: 0004h, Rate-B: 0008h

Default: 0000 0000h *

BIT FIELD	MODE	DESIGNATION	FUNCTION
D[16..00]	R/W	RATE CONTROL (Nrate)	Frequency control factor; 0-100,000
D[31..17]	R/W	(Reserved)	---

* Both rate generators default to 25.6MHz.

Table 3.6.1.6. Direct External Clocking

Sample Rate Fsamp (KSPS)	External Clock Frequency	Divisor Integer Ndiv
2-50	256 * Fsamp	2 thru 25
50-100	128 * Fsamp	1
100-200	64 * Fsamp	0

Table 3.9.1. Typical DMA Register Configuration; DMA Channel-0

PCI Offset	PCI Register	Function	Typical Value
80h	DMA Mode	Bus width (32); Interrupt on done	0002 0D43h
84h	DMA PCI Address	Initial PCI data source address	*
88h	DMA Local Address	Analog Input Buffer local address (Analog input buffer)	0000 0030h
8Ch	DMA Transfer Byte Count	Number of bytes in transfer	*
90h	DMA Descriptor Counter	Transfer direction; Local bus to PCI bus (Analog inputs)	0000 000Ah
A8h	DMA Command Status	Command and Status Register	0000 0001h 0000 0003h (See Text)

* Determined by specific transfer requirements.

Table 3.8.1. Interrupt Event Selection

INTERRUPT A[2:0]	INTERRUPT EVENT CONDITION
0	Initialization completed. Default state.
1	Autocal completed
2	Channels Ready
3	Data Buffer threshold flag, LOW-to-HIGH transition
4	Data Buffer threshold flag, HIGH-to-LOW transition
5	(Reserved)
6	(Reserved)
7	(Reserved)

Table 3.10.1. Channel Order (Active channels 00-07)

SAMPLE EVENT	CHANNEL ORDER	
	NON-SYNCHRONIZED SCANS (Typical)	SYNCHRONIZED SCANS
T _n	34567012	01234567
T _{n+1}	56701234	01234567
T _{n+2}	01234567	01234567
T _{n+3}	45670123	01234567
T _{n+4}	12345670	01234567

Table 3.11.1. Board Configuration Register**Offset: 0000 0024h****Default: 000X XXXXh**

BIT FIELD	DESCRIPTION
D00-D11	Firmware Revision
D12-D14	(Reserved status flags).
D15	High if PLL Rate generators are present; Low for Legacy generators.
D16	High if only 8 input channels are present.
D17	High if only 4 input channels are present.
D18	High if the board contains custom filter frequencies.
D19	High if configured for extended-temperature operation.
D20-D31	(Reserved)

APPENDIX B
SIMILARITIES TO PCI-24DSI32

APPENDIX B

SIMILARITIES TO PCI-24DSI32

Operation of the PMC-24DSI12 is similar to that of the PCI-24DSI32. This appendix summarizes the principal similarities and differences between the two products, and is provided as a general guide rather than a definitive list of requirements.

B.1. Comparison of Features

Table B.1 summarizes principal PCI-24DSI32 and PMC-24DSI12 features.

Table B.1. PCI-24DSI32, PMC-24DSI12 Features Comparison

Feature	PCI-24DSI32	PMC-24DSI12
Conversion resolution	24 Bits	24 Bits
Number of input channels	32	12
Sample rates	2-200 KSPS	2-200 KSPS
Input Ranges	±2.5V, 5V, 10V	±2.5V, 5V, 10V
Data Buffer	256K-Sample FIFO	256K-Sample FIFO
Adjustable Internal clocks	1	2
External clock and sync I/O	LVDS	LVDS, TTL
Autocalibration	On-demand	On-demand
Control Interface	PCI 2.3, D32, 33MHz	PCI 2.3, D32, 33MHz

B.2. Migration Issues

Paragraph 2.4.1 Interboard Connections:

Pin functions and mating connector are modified for a 68-Pin I/O connector.

Table 3.1. Control and Data Registers:

Rate Control registers are changed to RATE CONTROL A at 0004h, and RATE CONTROL B at 0008h.

Table 3.2. Board Control Register:

BCR, Bit D16:

Designation is changed from SYNCHRONIZE SCAN to ASYNCHRONOUS SCAN. Default input mode is scan-synchronized.

BCR, Bit D20:

New control bit D20 TTL EXT SYNC I/O, selects TTL sync I/O when HIGH, or LVDS sync I/O when LOW.

Table 3.6.1.1 Channel Groups:

Channel grouping is modified to accommodate a 12-channel board.

Table 3.6.1.2-1. Rate Assignments Register:

Channel groups 02 and 03 are eliminated.

Table 3.6.1.2-2. Rate Generator Assignment Codes:

Rate sources C and D are eliminated.

Paragraph 3.6.1.3. Sample Clock Generation:

Paragraph 3.6.1.4. Rate Generator Control:

There are now two rate generator categories: 'Legacy' and 'PLL.'

Paragraph 3.6.3 Multiboard Operation:

Logic levels for external clock and sync lines can now be configured as either TTL or LVDS.

Paragraph 3.10. Scan Synchronization:

Context change. Selection of scan synchronization is modified to reflect the revised ASYNCHRONOUS SCAN control bit in the BCR. Synchronous-sampling is now **disabled** when this bit is **HIGH**.

General Standards Corporation
High Performance Bus Interface Solutions

General Standards Corporation
Ph:(256)880-8787 FAX:(256)880-8788 Email: Solutions@GeneralStandards.com Web Site: <http://www.GeneralStandards.com>
MAN-PMC-24DSI12