

General Standards Corporation

High Performance Bus Interface Solutions

PMC-SIO4BX

Quad Channel High Performance Serial I/O PCI CARD
With up to 256Kbytes of FIFO buffering and Multiple Serial Protocols

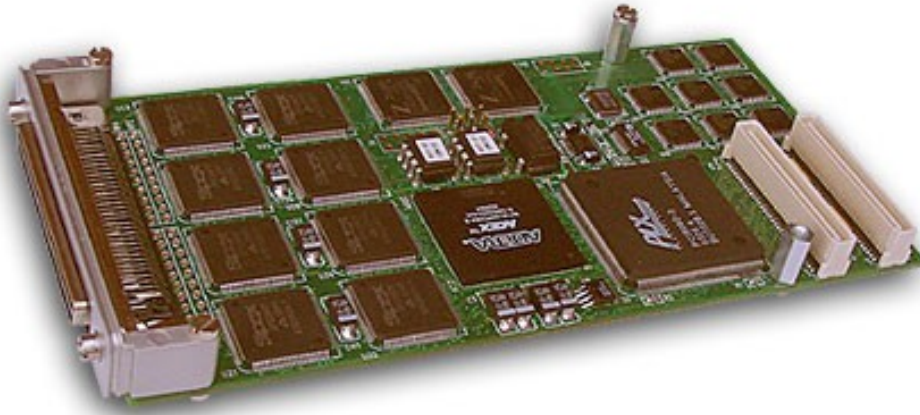

Features Include:

- Four Independent Multi-Protocol Serial Channels
- Synchronous Serial Data Rates up to 10 Mbits/sec
- Asynchronous Serial Data Rates up to 1 Mbit/sec
- Independent Transmit and Receive FIFOs for each channel - Up to 32 Kbytes each
- Serial Mode Protocols include Asynchronous, Bisync, SDLC, HDLC, IEEE 802.3, and Nine-Bit
- Multiprotocol Transceivers support RS422 (V.11)/RS485, RS423 (V.10), RS232 (V.28), V.35, RS530, as well as other Mixed Protocol modes.
- Parity and CRC detection capability
- Four Programmable Oscillators provide increased flexibility for Baud Rate Clock generation
- SCSI II type 68 pin front edge I/O Connector with optional cable adapter to four DB25 connectors
- Eight signals per channel, configurable as either DTE or DCE configuration: 3 Serial Clocks, 2 Serial Data signals, Clear-To-Send (CTS), Ready-To-Send(RTS), and Data Carrier Detect (DCD)
- Unused signals may be reconfigured as general purpose IO
- Fast RS422/RS485 Differential Cable Transceivers Provide Data Rate up to 10Mbps
- RS423 and RS232 Cable Transceivers Provide Data Rate up to 230kbps
- Industry Standard Zilog Z16C30 Multi-Protocol Universal Serial Controllers (USC®)
- Dual PCI DMA Engine to speed transfers and minimize host I/O overhead
- A variety of device drivers are available, including VxWorks, WinNT, Win2k, Linux, and Labview

General Standards Corporation
8302A Whitesburg Drive · Huntsville, AL 35802
Phone: (256)880-8787 or (800)653-9970
FAX: (256)880-8788
Email: sales@generalstandards.com

General Standards Corporation

High Performance Bus Interface Solutions

Applications Include:

- ✓ LAN/WAN Networking
- ✓ Telecommunications
- ✓ Serial Interface

Functional Description:

The PMC-SI04BX board is a four channel serial interface card which provides high speed, full-duplex, multi-protocol serial capability for PMC applications. The SIO4BX combines two multi-protocol Dual Universal Serial Controllers (USC®), 8 external FIFOs, and multi-protocol transceivers to provide four fully independent asynchronous or synchronous serial channels. These features, along with a high performance PCI interface engine, give the PMC-SI04BX unsurpassed performance in a serial interface card.

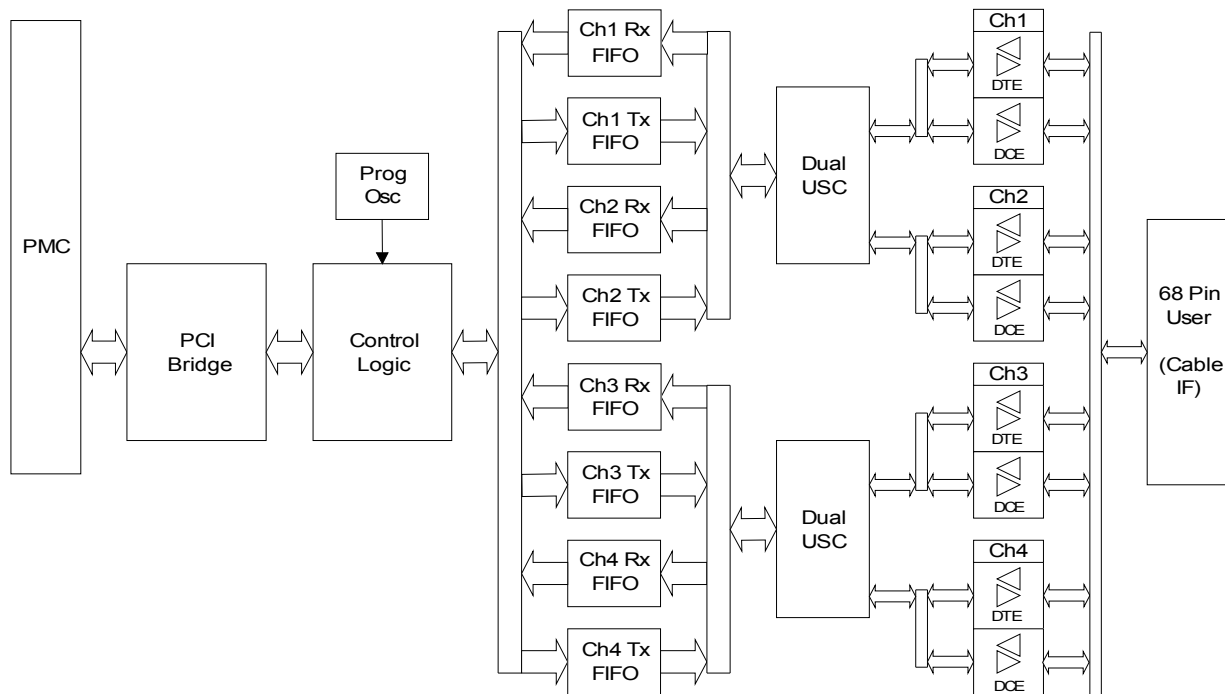

General Standards Corporation

8302A Whitesburg Drive - Huntsville, AL 35802

Phone: (256)880-8787 or (800)653-9970

FAX: (256)880-8788

Email: sales@generalstandards.com

General Standards Corporation

High Performance Bus Interface Solutions

USER I/O CONNECTIONS:

Pin #	DTE Signal	DCE Signal	Pin #	DTE Signal	DCE Signal
1	Ch1 RxClk +	Ch1 TxClk +	35	Ch3 RxClk +	Ch3 TxClk +
2	Ch1 RxClk -	Ch1 TxClk -	36	Ch3 RxClk -	Ch3 TxClk -
3	Ch1 DCDI +	Ch1 DCDO +	37	Ch3 DCDI +	Ch3 DCDO +
4	Ch1 DCDI -	Ch1 DCDO -	38	Ch3 DCDI -	Ch3 DCDO -
5	Ch1 CTS +	Ch1 RTS +	39	Ch3 CTS +	Ch3 RTS +
6	Ch1 CTS -	Ch1 RTS -	40	Ch3 CTS -	Ch3 RTS -
7	Ch1 RxD +	Ch1 TxD +	41	Ch3 RxD +	Ch3 TxD +
8	Ch1 RxD -	Ch1 TxD -	42	Ch3 RxD -	Ch3 TxD -
9	Ch1 RxC +	Ch1 TxC +	43	Ch3 RxC +	Ch3 TxC +
10	Ch1 RxC -	Ch1 TxC -	44	Ch3 RxC -	Ch3 TxC -
11	Ch1 RTS +	Ch1 CTS +	45	Ch3 RTS +	Ch3 CTS +
12	Ch1 RTS -	Ch1 CTS -	46	Ch3 RTS -	Ch3 CTS -
13	Ch1 TxD +	Ch1 RxD +	47	Ch3 TxD +	Ch3 RxD +
14	Ch1 TxD -	Ch1 RxD -	48	Ch3 TxD -	Ch3 RxD -
15	Ch1 TxC +	Ch1 RxC +	49	Ch3 TxC +	Ch3 RxC +
16	Ch1 TxC -	Ch1 RxC -	50	Ch3 TxC -	Ch3 RxC -
17	GND	GND	51	GND	GND
18	GND	GND	52	GND	GND
19	Ch2 CTS +	Ch2 CTS +	53	Ch4 CTS +	Ch4 CTS +
20	Ch2 CTS -	Ch2 CTS -	54	Ch4 CTS -	Ch4 CTS -
21	Ch2 RxD +	Ch2 TxD +	55	Ch4 RxD +	Ch4 TxD +
22	Ch2 RxD -	Ch2 TxD -	56	Ch4 RxD -	Ch4 TxD -
23	Ch2 RxC +	Ch2 TxC +	57	Ch4 RxC +	Ch4 TxC +
24	Ch2 RxC -	Ch2 TxC -	58	Ch4 RxC -	Ch4 TxC -
25	Ch2 RTS +	Ch2 CTS +	59	Ch4 RTS +	Ch4 CTS +
26	Ch2 RTS -	Ch2 CTS -	60	Ch4 RTS -	Ch4 CTS -
27	Ch2 TxD +	Ch2 RxD +	61	Ch4 TxD +	Ch4 RxD +
28	Ch2 TxD -	Ch2 RxD -	62	Ch4 TxD -	Ch4 RxD -
29	Ch2 TxC +	Ch2 RxC +	63	Ch4 TxC +	Ch4 RxC +
30	Ch2 TxC -	Ch2 RxC -	64	Ch4 TxC -	Ch4 RxC -
31	Ch2 DCDI +	Ch2 DCDO +	65	Ch4 DCDI +	Ch4 DCDO +
32	Ch2 DCDI -	Ch2 DCDO -	66	Ch4 DCDI -	Ch4 DCDO -
33	Ch2 RxClk +	Ch2 TxClk +	67	Ch4 RxClk +	Ch4 TxClk +
34	Ch2 RxClk -	Ch2 TxClk -	68	Ch4 RxClk -	Ch4 TxClk -

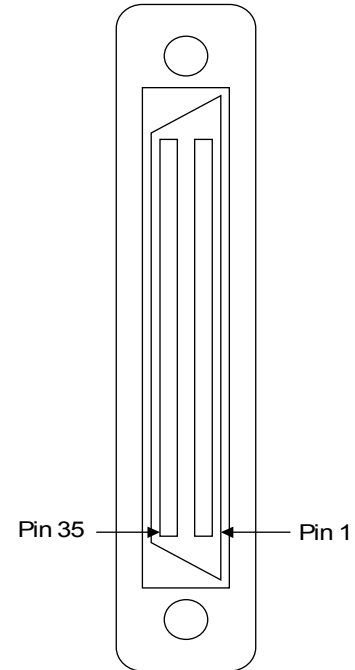

**PMC-SIO4BX
User Connector**

The user interface connections on the SIO4BX is a SCSI III type 68-pin connector (female) mounted to the front edge of the board (P2). The part number for the 68 pin front edge connector is AMP 787170-7. The mating connector is AMP 749111-6 or equivalent. The tables below show the pinout for the RS485/RS422. Single Ended signals (RS-423 and RS-232) use the negative side (-) of the differential pair.

General Standards Corp.
8302A Whitesburg Drive
Huntsville, AL 35802

General Standards Corporation assumes no responsibility for the use of any circuits in this product. No circuit patent licenses are implied. Information included herein supersedes previously published specifications on this product and is subject to change without notice.

General Standards Corporation
8302A Whitesburg Drive - Huntsville, AL 35802
Phone: (256)880-8787 or (800)653-9970
FAX: (256)880-8788
Email: sales@generalstandards.com